

TECHNICAL PAPER

Storage Capacitor Properties and Their Effect on Energy Harvester Performance

Radovan Faltus
Miroslav Jáně
Tomáš Zedníček

Technical Marketing

AVX Czech Republic s.r.o., Dvorakova 328,
563 01 Lanskrout, Czech Republic

Abstract:

The development of energy harvesters has quickened up in the last few years mainly due to semiconductor improvements. But power sources for energy harvesters usually exhibit high internal impedance and can therefore only deliver low currents. The most important consideration for harvesting is that the power consumption of the controller circuitry must be less than the energy generated by the power source. Energy harvesters use a storage capacitor slowly charged from power source through the controller and the leakage current of this capacitor is wastes a certain percentage of the generated energy. This paper will evaluate this effects of different technology capacitors on energy harvester performance.

1. Introduction

Wireless sensor modules using energy harvesters instead of a battery are often embedded in aeroplane wings for structural analysis, in car wheels to detect proper tyre pressure or in remote weather or traffic measuring units. Such devices are more convenient and efficient when powered wirelessly or self-powered. Three methods of energy harvesting for this purpose are most common: inductive charging, piezoelectric and thermal.

Inductive charging is an old technology, typically using transformers. However, to transfer high power a long distance between two coils there is new method called MIT Wireless Electricity. This technology works by transmitting electricity as a magnetic field oscillating at a specific frequency. Through a magnetically-coupled resonance, the "receiver" can capture the electricity, making for an efficient and safe method of over-the-air transfer. The thermal energy harvesting method is a lucrative approach because it is a fully self-sustainable form of DC power. Typically, a temperature differential is applied across a Peltier cell power source.

Piezoelectric energy harvesting was developed using a piezoelectric element and modern harvester controller/voltage converter. This method is getting more popular because the performance of piezo generators has been boosted and low power consumption semiconductor controllers have emerged.

In order to evaluate the suitability of different technologies to fulfill the storage function in a piezoelectric energy harvester circuit, the following modern-technology parts were chosen:

Tantalum-Polymer - good capacitance/ESR performance;

Niobium-Oxide - high reliability/robustness;

Tantalum-MnO₂ - standard and low ESR types representing good volumetric efficiency and long life;

Professional Tantalum-MnO₂ capacitor - increased reliability and low DCL;

Ceramic multilayer - ultra-low ESR and low DCL.

2. Piezoelectric generator

2.1. Piezo principle

The development of piezoelectric materials has enabled the construction of modern devices capable of generating sufficient voltages and currents for energy harvesting. A piezoelectric element consists of two conductors made of metal and piezoelectric material layers. In order to create a generator, typically one end of the strip element active zone is mechanically fixed and the opposite end is loaded with small metal ballast to create a mechanical resonance system. The mechanical system has tendency to vibrate at the resonant frequency even when frequency of the actuating vibrations varies and is irregular, and maximum energy is produced at resonant frequency. Energy generated by the voltage waveform is dependent mechanical deflection of the piezo element at the specific frequency.

2.2. Experimental solution

Initially, a frame for the chosen piezoelectric element, PFCB-W14 (Ref. 1), was constructed. The black end with output wires (Fig. 1) was mechanically fixed and the opposite end of the active zone was placed 6mm above small electromagnet mounted to the base. As the

element's body is made of a magnetic alloy, a small electromagnet acts as a very good actuator, bending the piezo strip to cause an amplitude of approximately 2mm at the end of active zone.

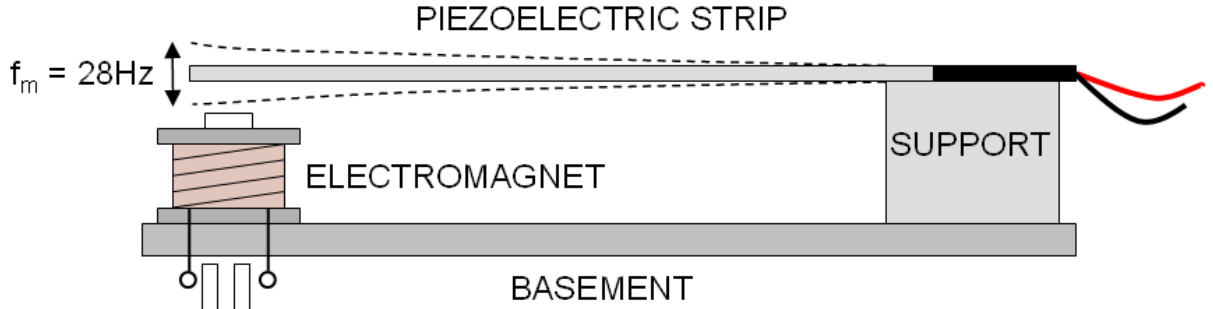
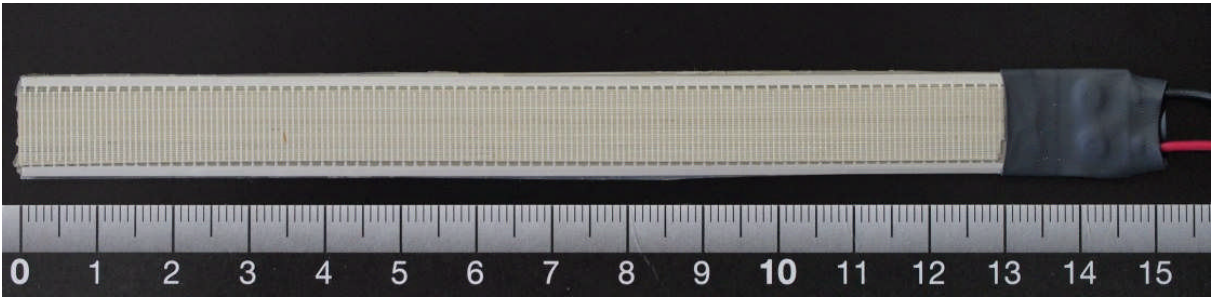

Figure 1: Experimental piezoelectric generator using PFCB-W14 element

Electromagnetic inductance would act as a parasitic effect in this experiment, but in this case, as the element core body does not close any inductive loop it will not induce any voltage in the electromagnet coil, (proven by oscilloscope measurement for a fixed 0mm mechanical amplitude). The electromagnet was actuated from a square wave voltage generator with adjustable frequency. The frequency was tuned in order to reach the mechanical self-resonance that exhibited the highest efficiency measured by AC peak-to-peak voltage. The highest no-load piezo element voltage $V_{pp} = 31.4\text{V}$ was reached at frequency $f_m = 28\text{Hz}$, see oscillograph in Figure 2 (measured using an Agilent Infiniium oscilloscope 54830B (Ref. 4) as with all other oscillographs.)

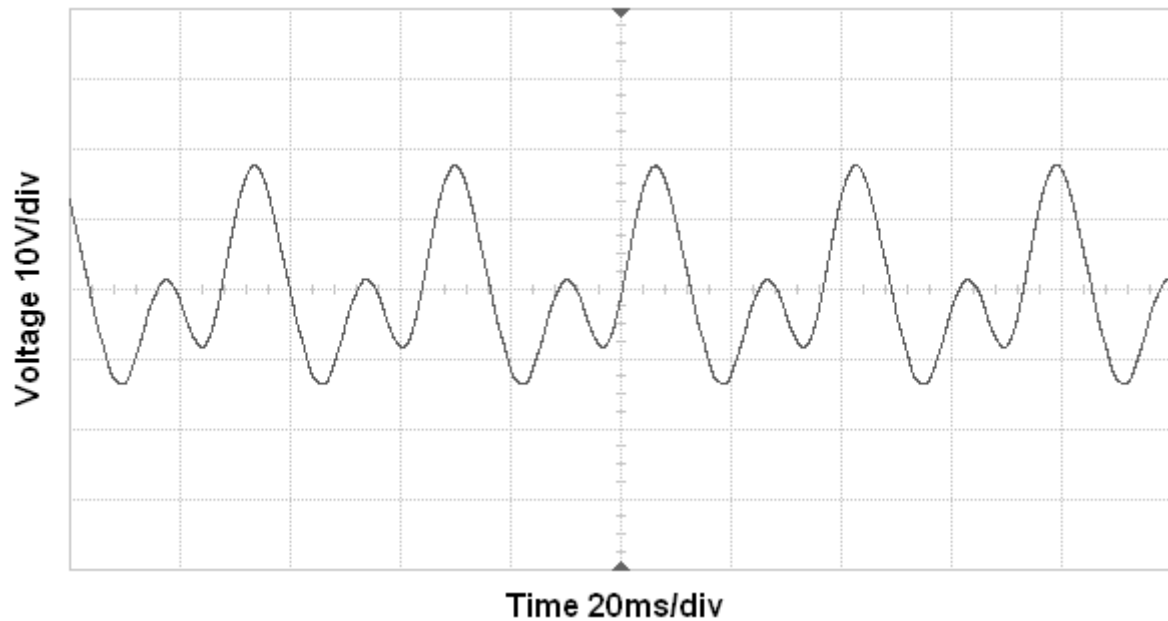

Figure 2: AC no-load output voltage of the PFCB-W14 piezo element

The internal resistance of the piezoelectric element is so high that it causes significant voltage drop when the element is loaded. Figure 3 shows the oscillograph with the generated output voltage when loaded by resistor $R_1 = 1k\Omega$. The RMS voltage $V_{rms1} = 37.3mV$ and RMS current $I_{rms1} = 37.3\mu A$.

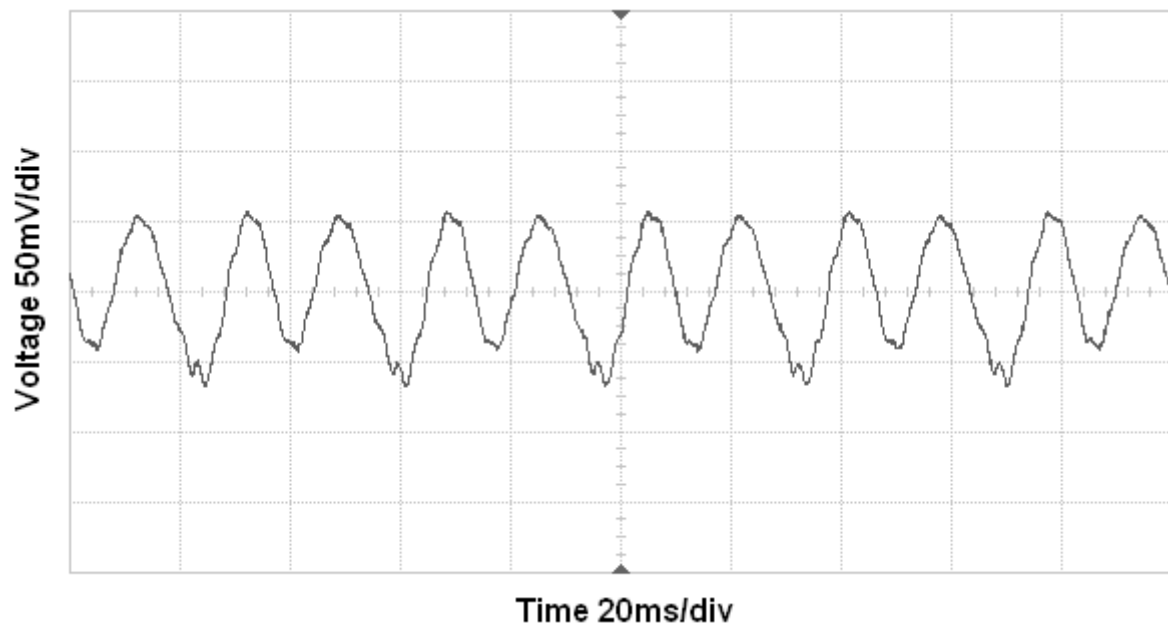

Figure 3: AC output voltage of the PFCB-W14 piezo element when loaded by 1kΩ resistor

3. Energy harvesting circuit

3.1 Overview

A modern energy harvesting system consists of four main blocks (see Figure 4):

- 1) Energy source with an output current that is insufficient to use as a direct power supply -therefore harvesting is required
- 2) Rectifier to create DC voltage suitable for energy storage
- 3) Energy storage circuit using storage capacitor
- 4) DC/DC buck converter to transform the storage voltage to the required output voltage

An energy generator behaves as a current source with a high internal resistance. It charges an energy storage capacitor driven through a rectifier. The storage capacitor voltage is measured using an under-voltage lockout circuit which enables the function of the output DC/DC converter when the stored energy is sufficient for converting to the output; conversely, it blocks the function of the output DC/DC converter when the stored energy is not sufficient for conversion. Thus we can recognize two main phases in energy harvester functionality: Charging/Output power-off and Output power-on.

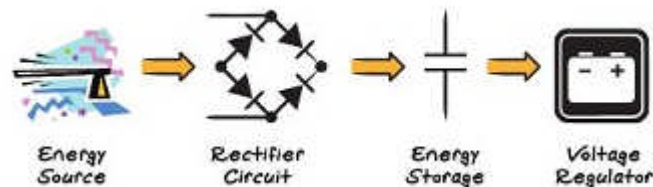

Figure 4: Principle of the energy harvesting system

3.2. Experimental solution

Figure 5 shows the actual measuring circuit using evaluation kit DC1459B-A (Ref. 3), specially dedicated for piezoelectric energy harvesting with DC/DC converter LTC3588-1 (Ref. 2). The output voltage was set to 1.8V to feed an output load consisting of series resistor $R_L = 2k\Omega$ and red LED with threshold voltage $V_t = 1.5V$. The series resistor was selected specifically to gain a resulting pulse ratio (Charging phase/LED-On phase) of approximately 1:1 (see Figure 6).

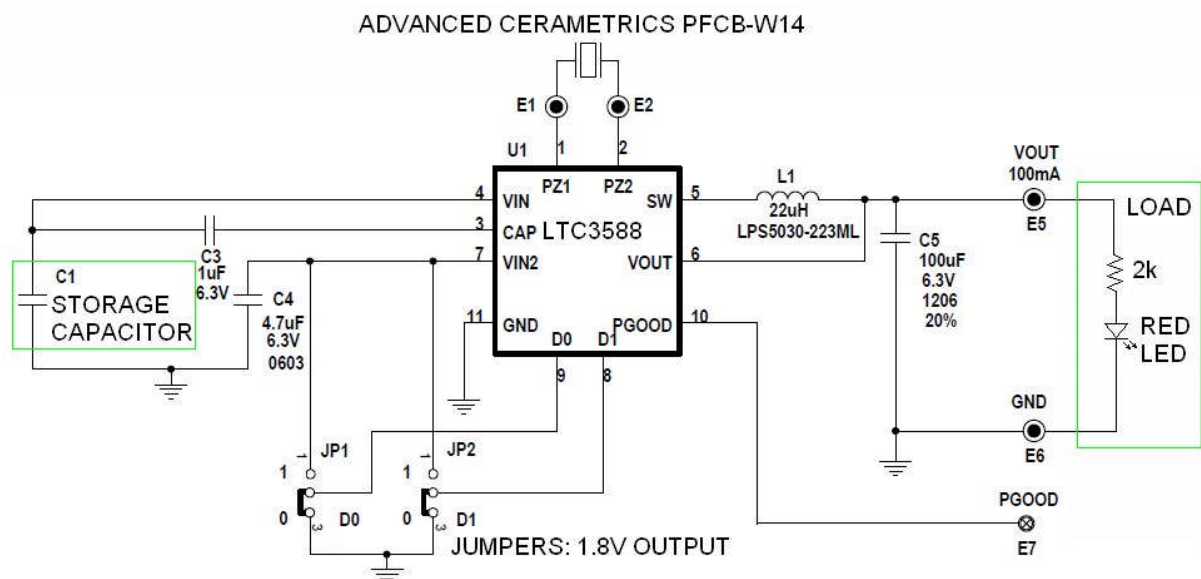

Figure 5: Schematic of the actual measuring circuit using evaluation kit DC1459B-A

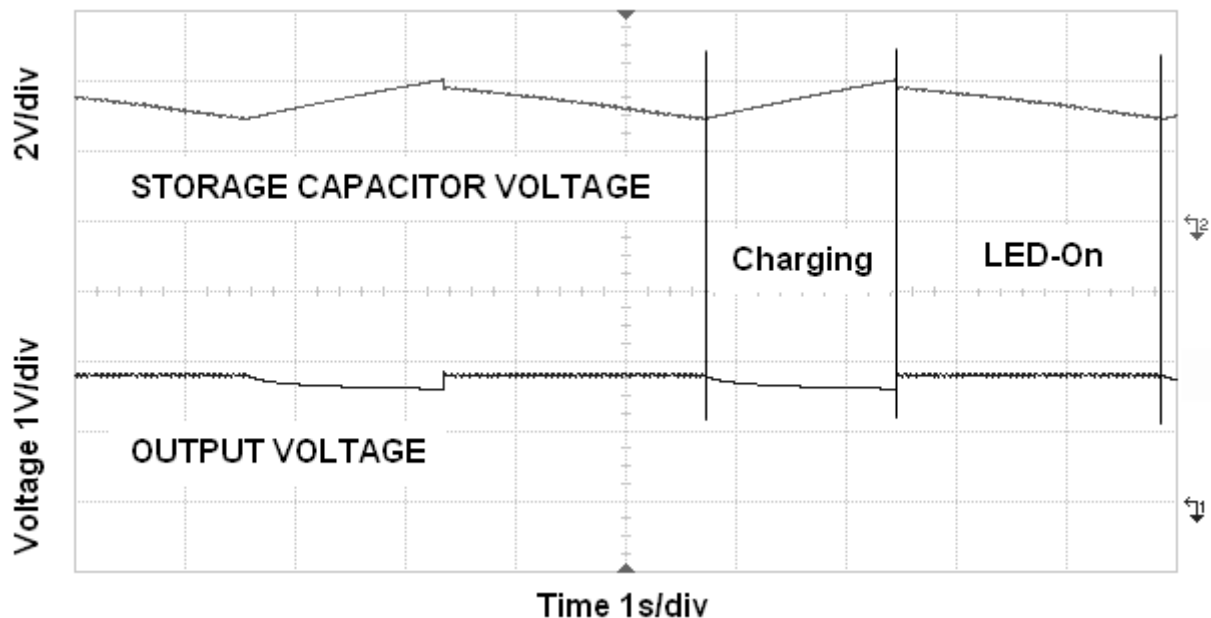

Figure 6: Output voltage and Storage capacitor voltage showing Charging phase and LED-On phase. NOTE: 0V indicators ('1', '2')

The output voltage changed values between 1.5V (LED threshold voltage – LED off) and 1.8V when the LED was emitting light driven by current $I_{L\text{On}} = 150\mu\text{A}$. The storage capacitor voltage changed between 4V (fully charged, ready to switch power to output) and 3V (LED goes off).

4. Storage capacitors benchmarked

The capacitors selected for the benchmark were chosen to represent different technologies exhibiting different levels of leakage current (DCL) and Equivalent Series Resistance (ESR). The leakage current of the capacitors was measured for steady state at 3.5V corresponding to their voltage working range and the ESR was measured at $f_c = 100\text{Hz}$, close to the piezo-generator frequency $f_m = 28\text{Hz}$. The parameters of all the chosen capacitors are

listed in Table 1. All the capacitors have $C = 22\mu\text{F}$ and rated voltage $V_r = 16\text{V}$ (except Niobium Oxide NOJ with $V_{rN} = 10\text{V}$) in order to achieve the approximate 1:1 Charging/LED-On ratio and LED-On frequency suitable for oscilloscope measurement.

Table 1: List of selected storage capacitors and their observed parameters

Type of capacitor	Technology	Series	DCL [nA]	ESR [mOhms]
TCJB226M016R0150	Tantalum-Polymer	TCJ	52	785
NOJB226M010R0150	Niobium Oxide	NOJ	39	1468
TAJB226M016R0150	Tantalum-MnO ₂	TAJ	29	1390
TPS226M016R0600	Tantalum-MnO ₂ low ESR	TPS	21	1130
TRJB226M016RRJ	Tantalum-MnO ₂ Professional	TRJ	14.4	820
1206YD226MAT2A	Ceramic	X5R	9.1	715

5. The effect of storage capacitor properties on the charging time and the LED-On time

The measurement circuit using various different capacitors (see Table 1) positioned at C1 (Fig. 5) exhibited different Charging and LED-On phases of the working period as displayed on oscillographs (Fig. 6 and 7), summarized in Table 2.

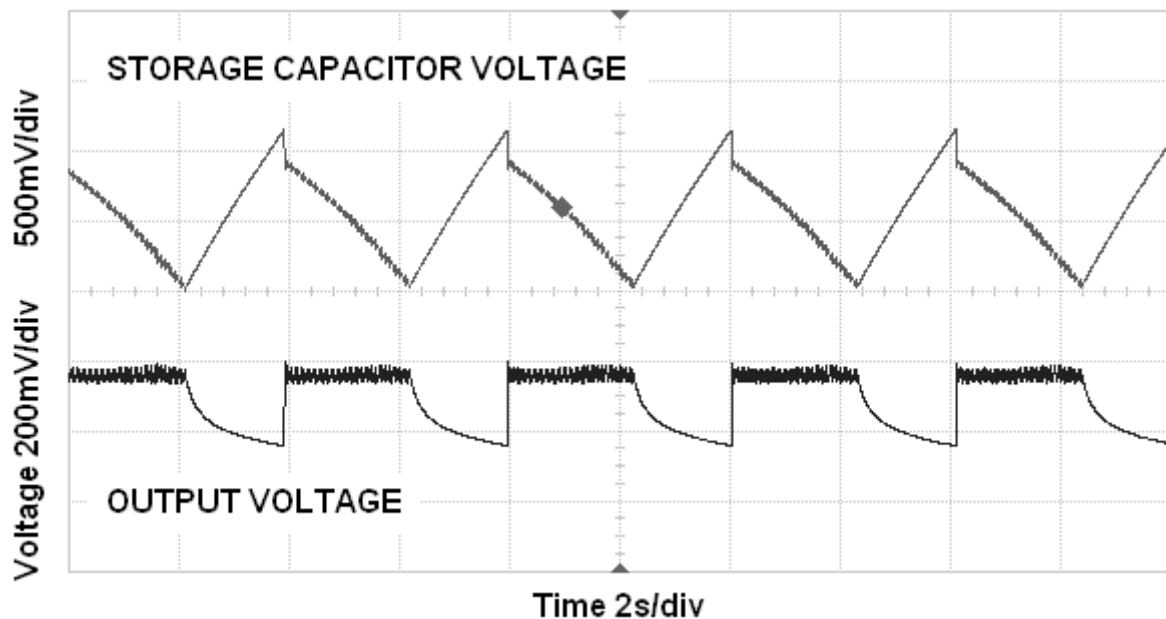

Figure 7: Output and Storage capacitor voltage showing Charging and LED-On phase for Professional Tantalum capacitor TRJB226M016R

Table 2: Charging time and LED-On time values for benchmarked storage capacitors

Type of capacitor	Technology	Series	Charging time [s]	LED-On time [s]
TCJB226M016R0150	Tantalum-Polymer	TCJ	2.36	1.93
NOJB226M010R0150	Niobium Oxide	NOJ	2.51	1.96
TAJB226M016R0150	Tantalum-MnO ₂	TAJ	2.47	1.67
TPS226M016R0600	Tantalum-MnO ₂ low ESR	TPS	2.40	1.71
TRJB226M016RRJ	Tantalum-MnO ₂ Professional	TRJ	1.78	2.33
1206YD226MAT2A	Ceramic	X5R	1.82	2.15

The leakage current of the capacitor affects the charging time of the capacitor and also the usable output LED-On time. The lower the leakage current the shorter the charging period and the longer the LED-On emitting period. This relationship trend is displayed in green in Figures 8 and 9. (The effect of ESR was not proven by these measurements.)

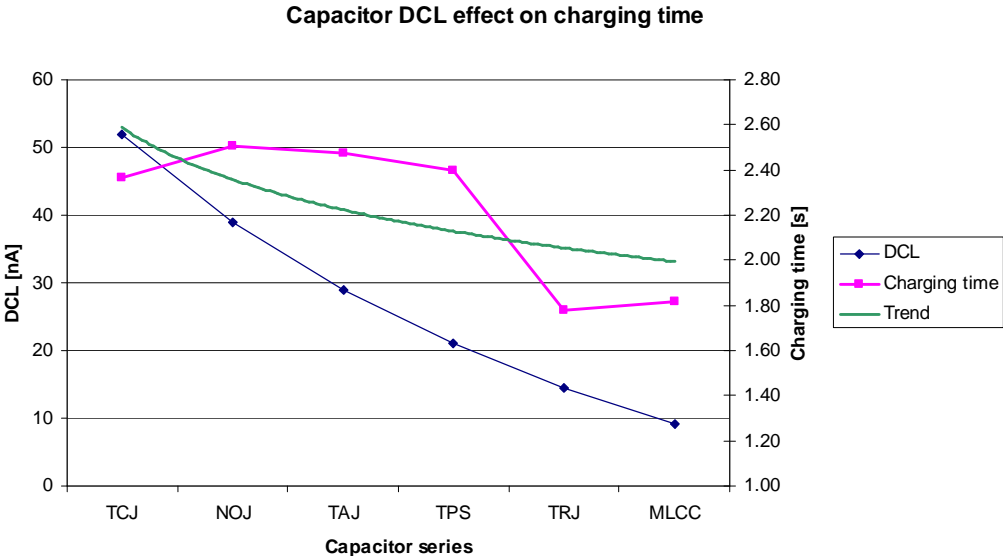

Figure 8: Storage capacitor DCL effect on charging time

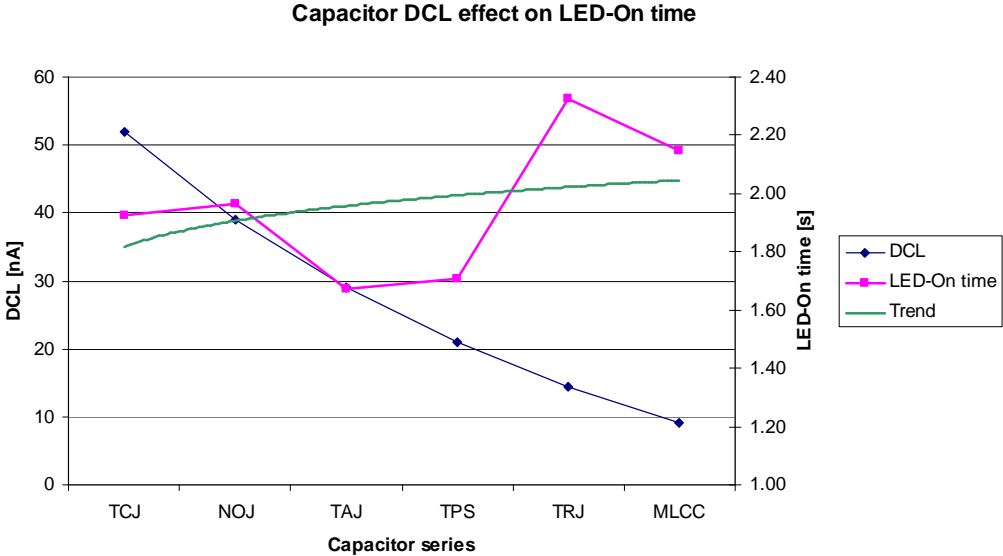

Figure 9: Storage capacitor DCL effect on LED-On time

Certain irregularities the relationship between static DCL and Charging time/LED-On time can be explained by actual leakage current fluctuations during the working cycles, so the effective value can be floating comparing to pre-measured steady state value.

6. Summary

Table 3: Performance of the energy harvester with various storage capacitors

Technology	Charging time [s]	LED-On time [s]
Tantalum-Polymer	0	0
Niobium Oxide	0	0
Tantalum-MnO ₂	0	-
Tantalum-MnO ₂ low ESR	0	-
Tantalum-MnO ₂ Professional	++	++
Ceramic	+	+

Explanation: ++ very good, + good, 0 neutral, - not good

The best performance was achieved with Tantalum TRJ professional capacitor which exhibited a relatively low leakage current at working voltage. The next best capacitor technology was MLCC. All other technologies were some way behind when considering Charging time performance. Tantalum-MnO₂ capacitors - standard and low ESR types (TAJ and TPS families) - exhibited slightly worse LED-On time than all other technologies.

7. Conclusion

Practical experiment has confirmed a low leakage current (DCL) as the most important parameter when determining which storage capacitor technology to use for energy harvesting applications. Low leakage current is especially important when the energy source delivers low currents that are not significantly higher than the DCL itself, and when the required output power-on time is comparable with the charging time or longer. The ESR of the capacitors tested did not produce any noticeable effect on energy harvester performance. Based on the results published in this paper, the best balanced combination of low DCL, sufficient capacitance and electrical parameter stability - which resulted in best energy harvester performance - was achieved using TRJ professional tantalum capacitors, which feature improved dielectrics.

References

- 1] Parameters of Advanced Ceramics piezoelectric element, http://www.advancedceramics.com/pages/product_line
- 2] Datasheet of Linear Technology LTC3588-1 piezoelectric energy harvesting power supply, <http://cds.linear.com/docs/Datasheet/35881fa.pdf>
- 3] Manual and description of Linear Technology DC1459B-A evaluation kit, <http://www.linear.com/demo/DC1459B-A>
- 4] Agilent Infiniium oscilloscope 54830B datasheet, <http://www.datasheetcatalog.org/datasheet2/9/0o4ptsp0alkuqg2rh3tp0wy3expy.pdf>



NORTH AMERICA
Tel: +1 864-967-2150

ASIA
Tel: +65 6286-7555

CENTRAL AMERICA
Tel: +55 11-46881960

EUROPE
Tel: +44 1276-697000

JAPAN
Tel: +81 740-321250

NOTICE: Specifications are subject to change without notice. Contact your nearest AVX Sales Office for the latest specifications. All statements, information and data given herein are believed to be accurate and reliable, but are presented without guarantee, warranty, or responsibility of any kind, expressed or implied. Statements or suggestions concerning possible use of our products are made without representation or warranty that any such use is free of patent infringement and are not recommendations to infringe any patent. The user should not assume that all safety measures are indicated or that other measures may not be required. Specifications are typical and may not apply to all applications.

WWW.AVX.COM