

# Medium Power Film Capacitors

## Application Notes

### INDUCTION HEATING

#### APPLICATIONS

Local thermal treatment, metallic surface hardening, pipe welding, tin coating treatment,...

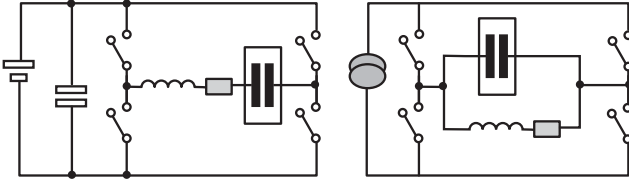

#### FUNCTION, PRODUCTS

##### DC Filtering

The purpose of this filter is to smooth the low frequency ripple coming from the bridge (up to 360 Hz) and to filter the high frequency ripple coming from the converter (15/20 kHz)\*.

\*Frequency will be lower than capacitor resonance frequency, on request, TPC can propose specific models for high frequency.

Main criteria are: High rms. current and good behavior against overvoltage are needed.

##### Products to offer

<b>FFG/FFH</b>	5 to 160µF	600 to 1900Vdc
<b>FFVE/FFWE</b>	12 to 400µF	300 to 1900Vdc
<b>FFVII/FFWI</b>	47 to 275µF	500 to 1100Vdc
<b>FFLI/FFLB</b>	58 to 800µF	680 to 1900Vdc
<b>FFLC</b>	1120 to 8800µF	680 to 1200Vdc

##### Tuning

In order to obtain the requested frequency, a capacitor is needed to tune with the inductance. The main characteristic of this capacitor is the reactive power (express in kVar) versus frequency.

##### Products to offer

<b>FAI6</b>	10 kHz ≤ F ≤ 100 kHz	1.5 to 60µF
		200 to 650Vrms
		160 to 1280kVar
<b>FAI1 to 4</b>	100 kHz ≤ F ≤ 500 kHz	110 to 4000nF
		300 to 600Vrms
		100 to 300kVar

### TRACTION

#### APPLICATIONS

Speed converter for power for mass transit and/or people mover system.

#### FUNCTION, PRODUCTS

##### DC Filtering

The purpose of the product is to filter the high frequency ripple coming from the converter in order to avoid rejection and perturbation on the network.

TPC has developed controlled-self healing range allowing reliable and competitive solution compare electrolytic technology.

See calculation example how to replace electrolytic technology.

Note that on new developments based on IGBT converter, manufacturer wish to have a main DC filter close to the converter and some light filters sprayed on the line.

##### Products to offer

Main DC Filter	<b>FFLC</b>	1120 to 8800µF	up to 1200Vdc
Additional DC Filter	<b>FFLI/FFLB</b>	58 to 800µF	up to 1900Vdc
	<b>FFVE/FFWE</b>	12 to 400µF	up to 1900Vdc
	<b>FFG/FFV</b>	5 to 160µF	up to 1900Vdc

##### Protection of semi-conductors

Overvoltage and clamping due to switching of semi-conductors.

##### Products to offer

Thyristors and GTO snubbers	<b>FPX/FPY</b>	0.5µF to 6µF	up to 4600V*
IGBT clamping	<b>FSB</b>	0.1 to 2.5µF	up to 2kVdc
	<b>FFVE</b>	12 to 400µF	up to 1.9kVdc

\*higher voltage on request

### POWER SUPPLIES AND RESONANT CONVERTER

#### APPLICATIONS

Medical	X-ray, scanner power supplies
Traction	Battery charger
Industrial	All application requesting power supplies

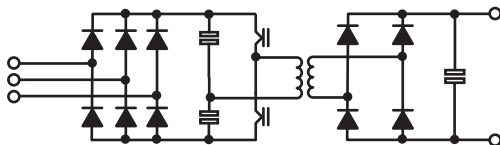
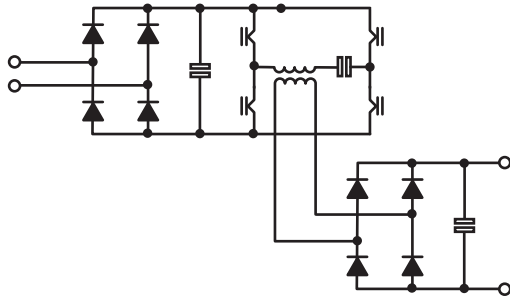

## Application Notes

### FUNCTION, PRODUCTS

#### DC Filtering

The purpose of this filter is to smooth the low frequency ripple coming from the bridge (up to 360 Hz) and to filter the high frequency ripple coming from the converter (15/20 kHz). High rms. current and good behavior against overvoltage are needed.

#### Products to offer

<b>FFB/FFV3</b>	1.5 to 160 $\mu$ F	75 to 1100Vdc
<b>FFG/FFH</b>	5 to 160 $\mu$ F	600 to 1900Vdc
<b>FFVE/FFWE</b>	12 to 400 $\mu$ F	300 to 1900Vdc
<b>FFVI/FFWI</b>	47 to 275 $\mu$ F	500 to 1100Vdc
<b>FFLI/FFLB</b>	58 to 800 $\mu$ F	680 to 1900Vdc

#### Tuning

In order to obtain the requested frequency, a capacitor is needed to tune with the inductance transformer.

The main characteristic of this capacitor is the reactive power and rms. current.

#### Products to offer

<b>FAV</b>	80 to 1200nF	up to 650Vrms
<b>FAI1 to 4</b>	110 to 4000nF	up to 600Vrms

#### Protection of semi-conductors

Overvoltage and clamping due to switching of semi-conductors.

#### Products to offer

IGBT clamping	<b>FSB</b>	0.1 to 3 $\mu$ F	up to 2kVdc
Mos-Fet transistor protection	<b>FSV</b>	10nF to 150nF	up to 2kVdc

### SPEED CONVERTER

#### APPLICATIONS

Speed converter for medium power (20 to 100kW)  
Traction: auxiliary converter for air cooling system, light,...  
Industrial: speed variation

### FUNCTION, PRODUCTS

#### DC Filtering

The purpose of this product is to filter the high frequency ripple coming from the converter in order to avoid rejection and perturbation on the network.

Due to IGBT converter, heavy rms. current and very compact product is requested; film technology is able to achieve these 2 targets.

#### Products to offer

<b>FFLI/FFLB</b>	58 to 800 $\mu$ F	680 to 1900Vdc
<b>FFVE/FFWE</b>	12 to 400 $\mu$ F	300 to 1900Vdc
<b>FFVI/FFWI</b>	47 to 275 $\mu$ F	500 to 1100Vdc
<b>FFB/FFV3</b>	1.5 to 160 $\mu$ F	75 to 1100Vdc

### WELDING

#### APPLICATIONS

Generate, out of the main supply, through a converter (chopper) and a transformer an overvoltage able to create an electrical arc.

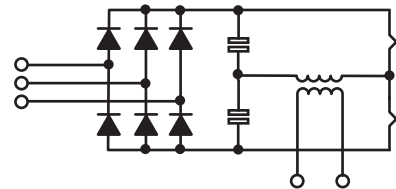
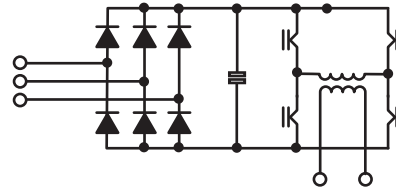

### FUNCTION, PRODUCTS

#### DC Filtering

The purpose of this filter is to smooth the low frequency ripple coming from the rectifier (up to 360 Hz) and to filter the high frequency ripple coming from the converter (15/20 kHz).

#### Products to offer

<b>FFVE/FFWE</b>	12 to 400 $\mu$ F	300 to 1900V
<b>FFVI/FFWI</b>	47 to 275 $\mu$ F	500 to 1100V
<b>FFB/FFV3</b>	1.5 to 160 $\mu$ F	75 to 1100V

### ELECTRICAL VEHICLE

#### APPLICATIONS

Battery powered car, electric fork lift truck and hybrid electric vehicle.

Due to high rms. current needed through the capacitor, metallized controlled self-healing technology will be an excellent solution.

See calculation example on page 58.

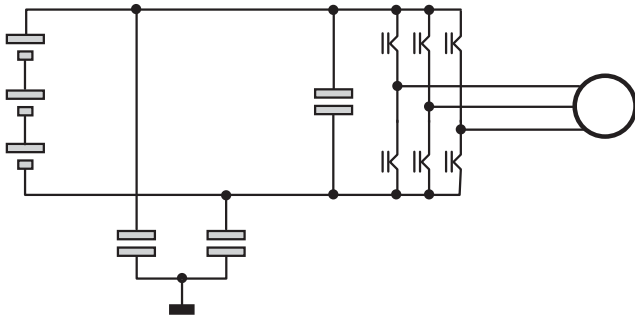

### FUNCTION, PRODUCTS

#### DC Filtering

Between battery and converter, a capacitor is needed. Its main purpose is to filter the ripple coming from the converter, to avoid damaging the battery. Metallized Film Capacitors are able to fulfill this function using 2 or 3 cases (only electrolytic can not).

#### Products to offer

<b>FFVE/FFWE</b>	12 to 400 $\mu$ F	300 to 1900Vdc
<b>FFVI/FFWI</b>	47 to 275 $\mu$ F	500 to 1100Vdc

According to quantity, a custom design could be developed, achieving the total function with a single case.

### WIND MILL

#### APPLICATIONS

Energy power supplied by the wind, new wind mill generation use electronic converter in order to control power, phase and voltage.

### FUNCTION, PRODUCTS

#### DC Filtering

The purpose of the product is to filter voltage ripple. TPC has developed controlled self-healing range allowing reliable and competitive solution compare electrolytic technology.

See calculation example how to replace electrolytic technology on pages 57 and 58.

#### Products to offer

<b>FFLC</b>	1120 to 8800 $\mu$ F	up to 1200Vdc
-------------	----------------------	---------------

#### Protection of semi-conductors

Overvoltage and clamping due to switching of semi-conductors.

#### Products to offer

Snubbers	<b>FSB</b>	0.1 to 3 $\mu$ F	up to 2kVdc
Clamping	<b>FFVE/FFWE</b>	12 to 400 $\mu$ F	up to 1.9kVdc

### ENERGY STORAGE

#### APPLICATIONS

Medical: cardiac defibrillator  
Industrial and military: laser telemetry, flash lamp

### FUNCTION, PRODUCTS

#### DC Filtering

Stored energy is used to generate electrical pulse.

#### Products to offer

<b>FDV1</b>	5 to 80 $\mu$ F	1000 to 1700V
<b>FDBB</b>	70 to 150 $\mu$ F	1800 to 3000V*

\*Specific FDBB can be offered with energy density over more than 1.5J per cc.

### FILM TECHNOLOGY TO REPLACE ALUMINUM ELECTROLYTIC TECHNOLOGY

The trend in the industrial and traction market for power conversion is to replace electrolytic capacitors by film technology. This trend is generated by the many advantages that film technology offers. Among these advantages, we have:

- \*High rms. current capabilities up to 1Arms. per  $\mu$ F
- \*Overvoltage withstanding up to 2 times the rated voltage
- \*Handle a reversal voltage
- \*High peak current capabilities
- \*No acid inside
- \*Long lifetime
- \*No storage problem

However, this replacement is not necessarily capacitance but for capacitance by application/Function.

Despite the advantages of film technology, replacement solutions won't be possible for each application, there will be several approaches to do this.

In order to help the use, we will present some examples where film gives a major benefit over electrolytic technology.

## Application Notes

### 1) DC LINK FILTER: HIGH CURRENT DESIGN & CAPACITANCE VALUE DESIGN

#### 1a) Energy supplied with batteries

Applications will be: electric car  
electric fork lift truck

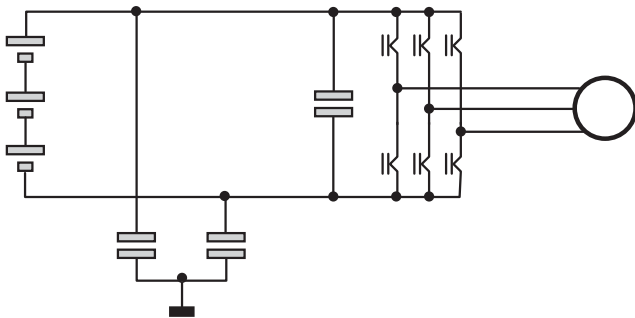

In that case, capacitor will be used as a decoupling capacitor. Film capacitor is particularly well adapted for this use, because main criteria for DC link capacitor will be rms. current withstanding.

It means that DC link capacitor can be designed on rms. current value.

If we take an electric car in account as example:

Requirement data:

Working voltage:	120Vdc
Ripple voltage allowed:	4Vrms
Rms. current:	80 Arms. @ 20kHz

Minimum capacitance value will be:

$$C = \frac{I_{rms}}{U_{ripple} \times 2 \times \pi \times f} = 159 \mu F$$

So, it will be easy to find a capacitance value close to these values.

Comparison with electrolytic capacitor.

If we take in account 20mA per  $\mu F$  for example, in order to handle 80 Arms, capacitance value minimum would be:

$$C = \frac{80}{0.02} = 4000 \mu F$$

#### 1b) Industrial motor drive, energy supplied from supply network

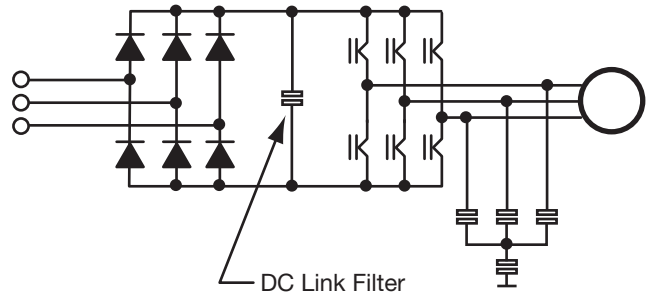

DC link voltage waveform:

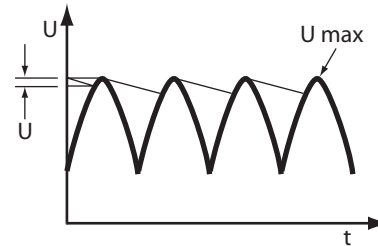

Capacitance value will be defined taken in account that supply frequency is lower than converter frequency.

To determine needed capacitance, we can use the following approached equation:

$$C = \frac{P_{load}}{U_{ripple} \times \left[ U_{max} - \frac{U_{ripple}}{2} \right] \times F_{rectifier}}$$

I<sub>rms</sub>. through capacitor will be (approached expression):

Of course this current doesn't take in account frequency converter current.

$$I_{rms} = \frac{U_{ripple}}{2 \times \sqrt{2}} \times C \times 2 \times \pi \times F_{rectifier} = \frac{P_{load} \times \pi}{\left[ U_{max} - \frac{U_{ripple}}{2} \right] \sqrt{2}}$$

So, with this approximation, I<sub>rms</sub>. through the capacitor will be depending of the Power of load, U<sub>max</sub> and U<sub>ripple</sub>.

## Application Notes

To illustrate, we will take a concrete example:

DC voltage 1000 Volts

U ripple 200 volts

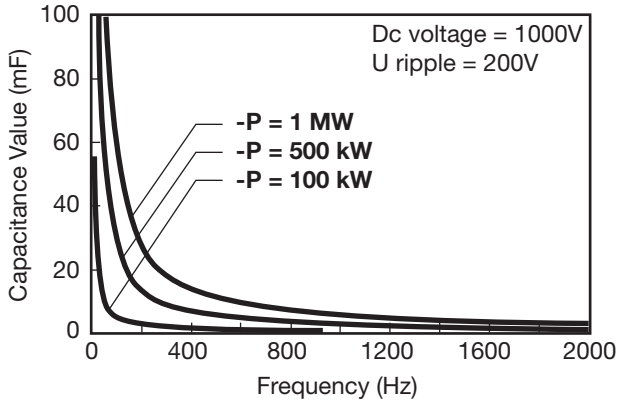

P	I <sub>rms</sub>
1 MW	2468 Arms
500 kW	1234 Arms
100 kW	247 Arms

It becomes necessary to have a zoom on low frequency:

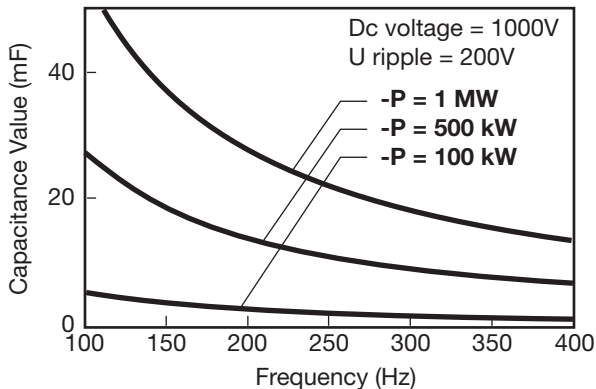

To compare with electrolytic solution, we will take a current capability of 20mA per  $\mu\text{F}$  for electrolytic capacitors. First case, power at 1Mwatt:

Rms. current is 2468 Arms, which would impose minimum capacitance value of 123.4mF (taking into account 0.02Arms. per  $\mu\text{F}$ ).

If we look at this value on the curve, we can see that this capacitance value is needed (the given example for film technology) for a rectifier frequency lower than 100Hz.

So, with 3 phases, 6 diodes rectifier, frequency will be 300Hz.

We can see on the 1 megawatt curve that capacitance needed is 18.5mF. Film solution will be almost 4 times smaller than electrolytic solution, with high reliability in addition.

Lower power will give similar results, and for power up to 10 kwatts, capacitance value becomes so small that film technology still constitutes the best solution.

Even at 100Hz rectifier frequency, no more than 555 $\mu\text{F}$  are needed, supply voltage and ripple still the same than previously.

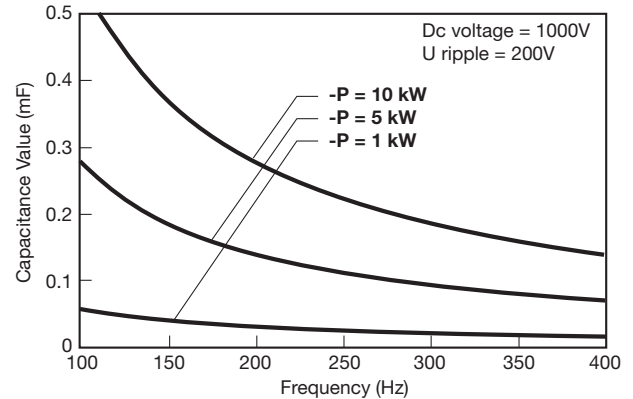

## 2) OVERVOLTAGE DESIGN

We will consider light traction application, like metro, tramway, electric buses, ...

DC link voltage wave form:

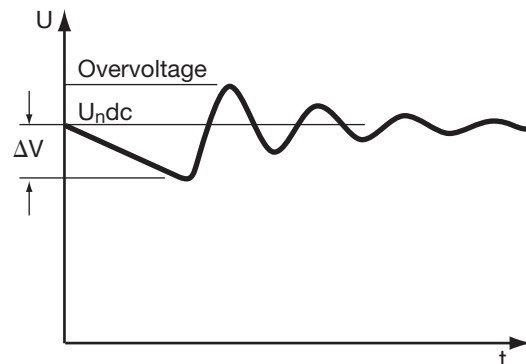
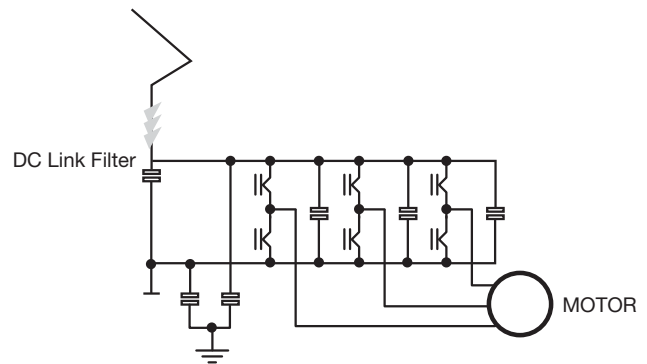

## Application Notes

Due to the principle of carrying the power from the catenary to the train, some contact discontinuity appears between pantograph and catenary.

When contact is not done, energy come from DC link filter, with for effect, to decrease the voltage. So, as soon as the contact is re-established, an overvoltage appears.

$$V(t) = U_{ndc} - \Delta V \times e^{-\alpha t} \times (\cos \omega t + \frac{\alpha}{\omega} \sin \omega t)$$

$$\text{with } \omega = \sqrt{\beta_0^2 - \alpha^2}$$

$$\beta_0 = \frac{1}{\sqrt{L \times C}}$$

$$\alpha = \frac{R}{2 \times L}$$

Worse case would be  $\Delta V =$  catenary voltage, because overvoltage could almost reach 2 times the rated voltage.

So, film capacitor can handle this kind of overvoltage.

Comparison with electrolytic technology:

Electrolytic handle 1.2 DC voltage max:

So minimum voltage that electrolytic should handle would be:

$$\text{DC voltage of electrolytic technology: } \frac{2 \times 1000V}{1.2} = 1670V$$

4 capacitors 450 Volts in series would be needed.

Volume occupied for 10mF with electrolytic would be: 26 l and Irms. max would be 220Arms.

With film, volume occupied would be 25 l, and rms. current capability would be higher than 500Arms.

In other hand, link to these overvoltages, peak current appear through the capacitor:

So, we have to calculate the energy generated by this overvoltage  $I^2t = \int i^2(t)dt$ .

$$i(t) = \frac{C\beta_0^2 V_0}{\omega} e^{-\alpha t} \sin \omega t$$

$$i^2(t) = \frac{C^2\beta_0^4 V_0^2}{\omega^2} e^{-2\alpha t} \sin^2 \omega t$$

$$\int_0^\infty i^2(t)dt = \left[ \frac{1}{4} \frac{e^{-2\alpha t} C^2\beta_0^4 V_0^2 (-\alpha^2 - \omega^2 + \alpha^2 \cos 2\omega t - \alpha \omega \sin 2\omega t)}{\alpha \omega^2 (\alpha^2 + \omega^2)} \right]_0^\infty$$

After few periods, current becomes null, then:

$$\int_0^\infty i^2(t)dt = [0] - \left[ -\frac{1}{4} \frac{C^2\beta_0^4 V_0^2}{\alpha (\alpha^2 + \omega^2)} \right] = \frac{1}{4} \frac{C^2\beta_0^4 V_0^2}{\alpha (\alpha^2 + \omega^2)}$$

$$\text{with: } \beta_0 = \frac{1}{\sqrt{L \times C}}; \alpha = \frac{R}{2 \times L}; \omega = \sqrt{\beta_0^2 - \alpha^2}$$

This energy calculation will be used for short circuit discharge between terminal as well. Such discharge will generate a very high peak current and some ringing that electrolytic could not handle.

### 3) VOLTAGE RATING

Function of the voltage rating needed, film solution will become more and more interesting.

If high capacitance value is requested, film solution will be less competitive. Indeed, if there is no overvoltage, low rms. current, large capacitance value, it will be difficult for film technology to be competitive below 900 volts.

### LIFETIME CALCULATION

Film technology allows a very long lifetime expectancy, depending on voltage load conditions (working voltage) and hot spot temperature.

For DC filtering, lifetime meets the curves shown in this catalog.

End of life criteria is a decrease of capacitance value of 2%. However, this is a theoretical end of life, because capacitor can be still used after this point. If application can allow 5% capacitance decrease, lifetime will be widely increased.

Hot spot temperature will be determined with the following expression:

$$\theta_{max_{hotspot}} = \theta_{ambient} + I_{rms}^2 \times \left[ r_s + \frac{1}{C \times 2 \times \pi} \times tg\delta_0 \right] \times R_{th}$$

with:  $\theta_{max_{hotspot}}$ : the maximum hot spot temperature

$tg\delta_0$ : dielectric losses

$R_{th}$ : Thermal resistance

$r_s$ : Serial resistance

$\theta_{hot spot}$  will be 85°C or 105°C function of the application and the technology.

### 4) CONCLUSION

This document gives some ways for the engineer designer to do their choice. Of course, for each case a complete calculation will have to be done.

Anyway, if the request is only capacitance value, low voltage, low rms. Current, no overvoltage, no reversal voltage, no peak current, film technology certainly won't be a good solution.