

TPC
Suppressor Capacitors
Classes X & Y

General Technical Information on Interference Suppression	2
Ordering Code	3
QX Series Range	4
BY Series Range	10

As we are anxious that our customers should benefit from the latest developments in the technology and standards, AVX reserves the right to modify the characteristics published in this brochure.

NOTICE: Specifications are subject to change without notice. Contact your nearest AVX Sales Office for the latest specifications. All statements, information and data given herein are believed to be accurate and reliable, but are presented without guarantee, warranty, or responsibility of any kind, expressed or implied. Statements or suggestions concerning possible use of our products are made without representation or warranty that any such use is free of patent infringement and are not recommendations to infringe any patent. The user should not assume that all safety measures are indicated or that other measures may not be required. Specifications are typical and may not apply to all applications.

General Technical Information

Electrical and electronic equipment which have rapid fluctuations in mains current, generate electromagnetic disturbances which cause radio interference over a large spectrum of frequency.

These disturbances can be caused by motors, thyristors, triacs, thermostats, neon tubes, or in general all equipment employing some means of commutation.

Interference from source to receiver is spread in three ways: along conductors, by coupling and by radiation. To frequencies of 30 MHz approximately, interference is spread mainly along the installed electrical conductors. In this range inductive and capacitive coupling also occurs between the conductors and other metallic parts of the devices acting as supports of interference transfer.

Frequencies higher than 30 MHz are spread by radiation since interference source dimensions and terminal conductors are in order of size to the wave length of the radiated

interference. The metallic parts, therefore, act as antennae.

In order to reduce these disturbances, which are inconvenient and sometimes serious, it is recommended and sometimes required that one or more suppression capacitors should be introduced into the mains circuit (see examples).

The second role is to protect the electrical system in which it is used against the surge voltage that may be caused by lightning. The energy in this case will be absorbed by the capacitor and not by the electrical circuit.

Standards organizations in many countries have studied the different problems caused, and defined their own requirements as to quality and performance of the capacitors.

Some of these organizations are as follows:

VDE (Germany) - ASE (Switzerland) - UL (USA)

CSA (Canada) - EN 132 400 (Europe).

TWO PRINCIPAL CLASSES OF CAPACITORS HAVE BEEN DEFINED.

- **Class "X"**

Capacitors intended for applications where a short circuit will not cause a dangerous electric shock.

- **Class "Y"**

Capacitors with greater mechanical and electrical security, which exclude short circuits within the capacitor. Capacitances are limited to reduce currents to a safe limit.

Depending on function, class "X" capacitors are connected between each line conductor, class "Y" between a conductor and earth or a metal element in the equipment.

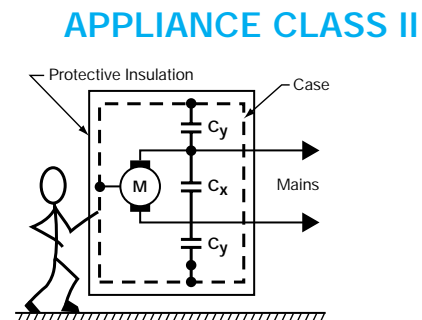
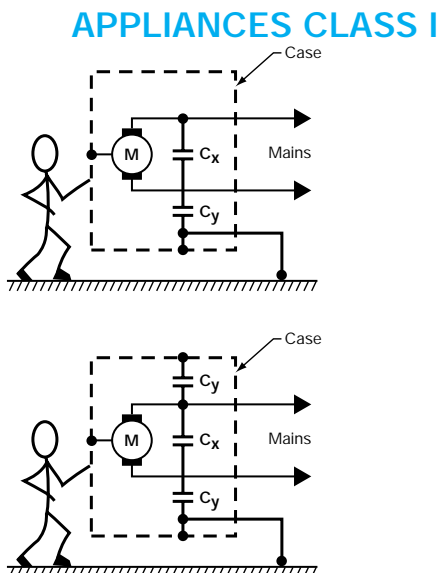

Cx: Suppression capacitors - Function (or class) X

Cy: Suppression capacitors - Function (or class) Y

The examples above show protection and suppression of a motor by using X and Y capacitors.

Suppressor Capacitors



Ordering Code

HOW TO ORDER

QX Series - Polyester

Example: 330 nF - 275 Vac 20%

QX



Type

22



Size

Pitch 10 mm = 10
Pitch 15 mm = 15
Pitch 22.5 mm = 22
Pitch 27.5 mm = 27

4



Dielectric Class
QX = 4
polyester

H



Voltage

QX = 275 V: H

0334



Capacitance EIA Code

1st digit = 0 (zero)
(2 significant digits plus number of zeros)

Examples
220,000pF = 224
330,000pF = 334

M



Tolerance

10%: K
20%: M

--



Suffix

--: Bulk with lead length
6 mm
EN: Taped on reel

Other existing suffix for different lead length up to 26 mm.

BY Series - Polypropylene

Example: 330 nF - 250 Vac 20%

BY



Type

22



Size

Pitch 10 mm = 10
Pitch 15 mm = 15
Pitch 22.5 mm = 22
Pitch 27.5 mm = 27

6



Dielectric Class
BY = 6
polypropylene

G



Voltage

BY = 250 V: G

0334



Capacitance EIA Code

1st digit = 0 (zero)
(2 significant digits plus number of zeros)

Examples
220,000pF = 224
330,000pF = 334

M



Tolerance

10%: K
20%: M

--



Suffix

--: Bulk with lead length
6 mm
EN: Taped on reel

Other existing suffix for different lead length up to 26 mm.

General Technical Data

DESCRIPTION

Metallized polyester film capacitor. Box made of solvent resistant and self-extinguishing UL 94 VO material.

APPLICATIONS

- For X2 electromagnetic interference suppression.
- Specially designed to meet the requirements of the NEW IEC 384-14 specification (2.5 kV peak pulse voltage test).
- Approved for 3 kV pulse test.

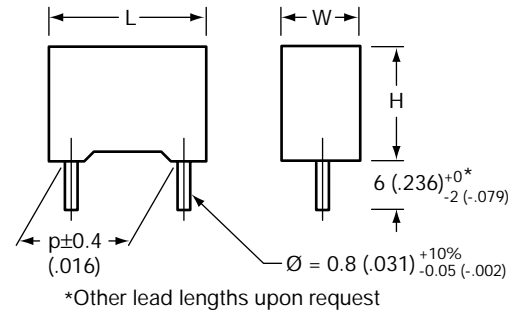

GENERAL CHARACTERISTICS

Capacitance range 1 nF to 2.2 μ F/E6 Series

Tolerance on capacitance $\pm 10\%$, $\pm 20\%$

Rated voltage 275 Vac

Temperature range -40°C to $+100^{\circ}\text{C}$

Climatic category 40/100/21

Safety class X2

CAPACITANCE RANGE

millimeters (inches)

Size	Capacitance	Dimension				Rated current at 50 Hz (mA)
		P ± 0.4 Pitch	L Length ± 0.4	H Height ± 0.3	W Width ± 0.4	
10	1 nF	10.0 (.394)	12.4 (.488)	9.9 (.390)	5.0 (.197)	0.10
	1.5 nF	10.0 (.394)	12.4 (.488)	9.9 (.390)	5.0 (.197)	0.15
	2.2 nF	10.0 (.394)	12.4 (.488)	9.9 (.390)	5.0 (.197)	0.22
	3.3 nF	10.0 (.394)	12.4 (.488)	9.9 (.390)	5.0 (.197)	0.33
	4.7 nF	10.0 (.394)	12.4 (.488)	9.9 (.390)	5.0 (.197)	0.47
	6.8 nF	10.0 (.394)	12.4 (.488)	13.4 (.528)	5.0 (.197)	0.68
	10 nF	10.0 (.394)	12.4 (.488)	13.4 (.528)	5.0 (.197)	1.00
15	10 nF	15.0 (.591)	17.4 (.685)	10.4 (.409)	5.0 (.197)	1.00
	15 nF	15.0 (.591)	17.4 (.685)	10.4 (.409)	5.0 (.197)	1.50
	22 nF	15.0 (.591)	17.4 (.685)	10.4 (.409)	5.0 (.197)	2.20
	33 nF	15.0 (.591)	17.4 (.685)	10.4 (.409)	5.0 (.197)	3.30
	47 nF	15.0 (.591)	17.4 (.685)	10.4 (.409)	5.0 (.197)	4.70
	68 nF	15.0 (.591)	17.4 (.685)	13.4 (.528)	5.0 (.197)	6.80
	100 nF	15.0 (.591)	17.4 (.685)	13.4 (.528)	6.1 (.240)	10.0
150 nF	15.0 (.591)	17.4 (.685)	14.4 (.567)	8.3 (.327)	15.0	
22	150 nF	22.5 (.886)	26.1 (1.03)	14.9 (.587)	7.3 (.287)	15.0
	220 nF	22.5 (.886)	26.1 (1.03)	14.9 (.587)	7.3 (.287)	22.0
	330 nF	22.5 (.886)	26.1 (1.03)	19.4 (.764)	9.8 (.386)	33.0
	470 nF	22.5 (.886)	26.1 (1.03)	19.4 (.764)	9.8 (.386)	47.0
27	470 nF	27.5 (1.08)	31.1 (1.22)	19.3 (.760)	9.8 (.386)	47.0
	680 nF	27.5 (1.08)	31.1 (1.22)	22.4 (.881)	12.9 (.508)	68.0
	1000 nF	27.5 (1.08)	31.1 (1.22)	22.4 (.881)	12.9 (.508)	100.0
	1500 nF	27.5 (1.08)	31.1 (1.22)	29.8 (1.17)	17.3 (.681)	150.0
	2200 nF	27.5 (1.08)	31.1 (1.22)	31.3 (1.23)	20.7 (.815)	220.0

MARKING

On upper edge

- Logo
- Capacitance
- Tolerance (except $\pm 20\%$) (EIA Code)
- Date Code





On one side

- Type: QX
- Rated Voltage: 275 V~
- Dielectric Code: MKT
- Self-healing Code: SH
- Capacitor Class: X2
- Climatic Category: GMF 40/100/21
- Approvals Brands

ELECTRICAL CHARACTERISTICS

Test Condition	Performance
Initial measurements at 20°C	<p>Capacitance C shall be within tolerance of the rated value at 1 kHz</p> <p>Dissipation Factor DF: 1% at 1 kHz 1.5% at 10 kHz 5% at 100 kHz</p> <p>Insulation Resistance IR after 1 mn/100 V for C ≤ 0.33 μF IR > 30 GΩ for C > 0.33 μF IR x C > 10,000 sec.</p>
<p>Dielectric strength at 20°C: between terminals: • 1 500 Vac for 2 sec. • 1 770 Vdc for 60 sec. • 2 125 Vdc for 2 sec.</p> <p>between terminals and case: • 2 500 Vac for 2 sec.</p>	No dielectric breakdown
Maximum rated dv / dt	100 V/μs

APPROVALS

	VDE EN 132 400	Class X2 capacitors	up to 1μF	File No. 94684
	IMQ EN 132 400	Class X2 capacitors	up to 1μF	File No. V 4492
	SEV EN 132 400	Class X2 capacitors	up to 1μF	File No. 96.1 10440.01
	CSA C22.2 N° 1-94	Across the line capacitors	up to 1μF	File No. LR 100430.8
	UL 1414	Across the line capacitors	up to 1μF	File No. E 184051
<p>CSA and UL approved with a voltage of 250 Vac only. Approved according to EN 132 400 (IEC 384-14, 2nd Edition 1993).</p>				

TESTS RELATED TO IEC 384 -14 (2ND EDITION '93) AND EN 132 400

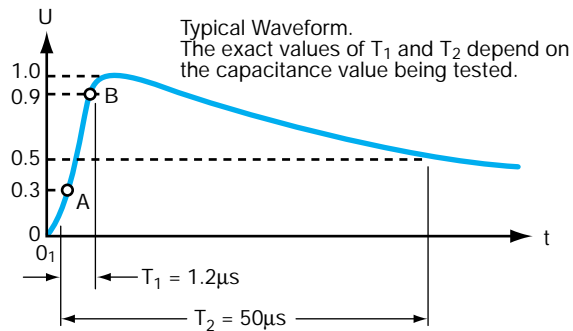

According to IEC 384-14 (2nd Edition 1993) and EN132400 our X2 suppression capacitors withstand the following tests (type test):

Impulse voltage test (before endurance test)

$V_{PEAK} = 2.5 \text{ kV}$ (Class X2)

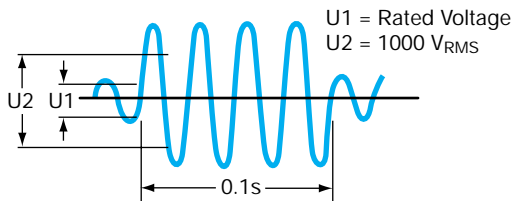

Endurance test

The capacitors are tested for 1000 hours at upper category temperature with a voltage of $1.25 \times U_R$ for Class X2.

Every hour the test voltage is increased up to $1000 V_{RMS}/50 \text{ Hz}$ for a period of 0.1s.

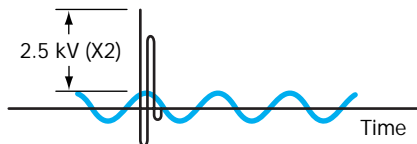

Active flammability test

The capacitors are tested at the rated voltage (V_{ac}) at 50 Hz with superimposed 20 pulses at 2.5 kV for Class X2 with an interval between the successive pulses of 5 seconds.

The rated voltage is kept for 2 min. after the last discharge. At the end of the test the capacitor does not burn (control made with the cheesecloth wrapped on the body of capacitors).

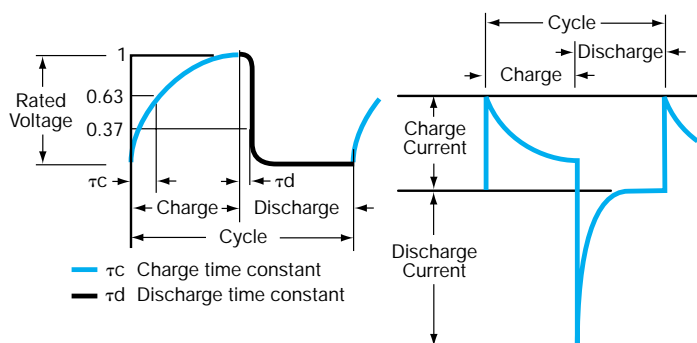

Charge and discharge test

The capacitors are subjected to 10,000 cycles of charge and discharge at the rate of approximately one operation per second.

Characteristics vs. Temperature (Typical Curves)

CAPACITANCE CHANGE vs. TEMPERATURE

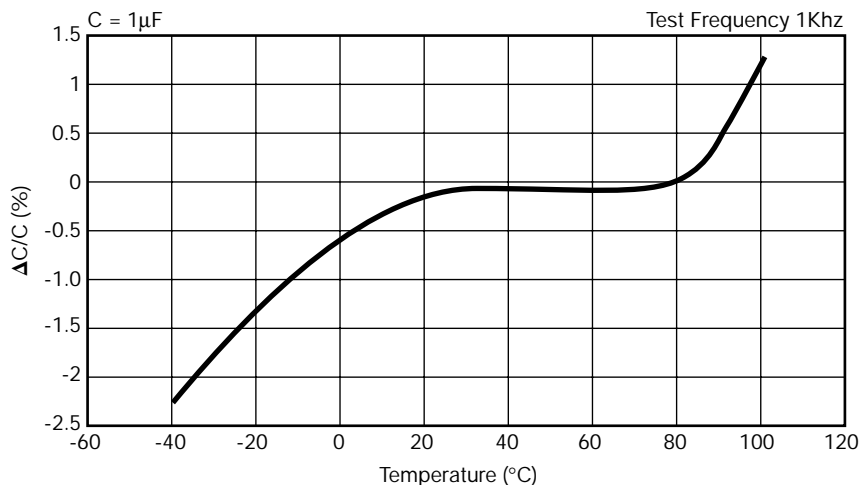

DISSIPATION FACTOR vs. TEMPERATURE

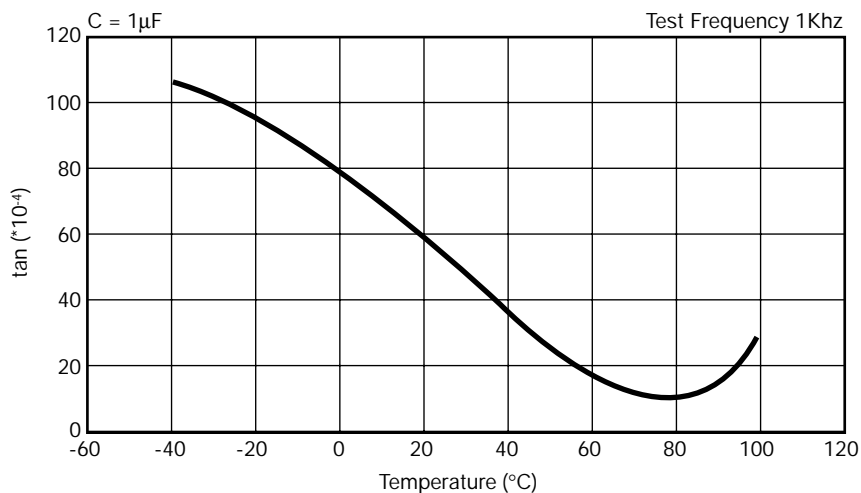

INSULATION RESISTANCE vs. TEMPERATURE

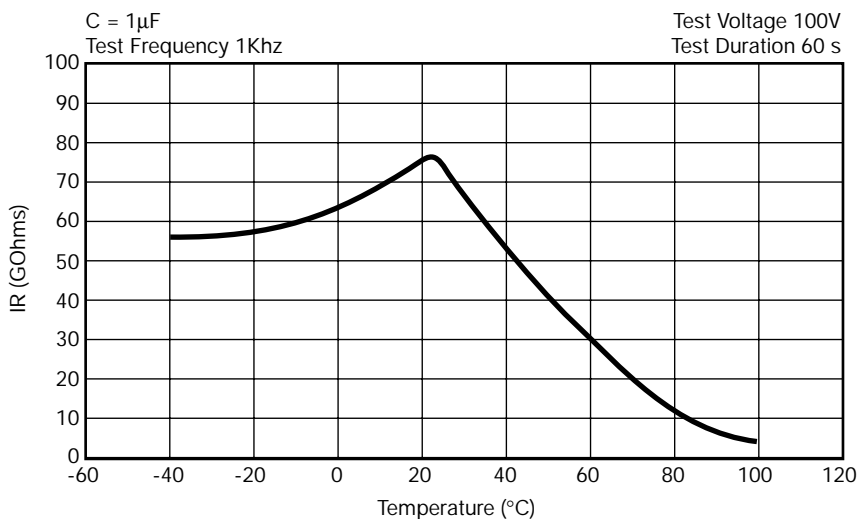

Characteristics vs. Frequency

CAPACITANCE CHANGE vs. FREQUENCY

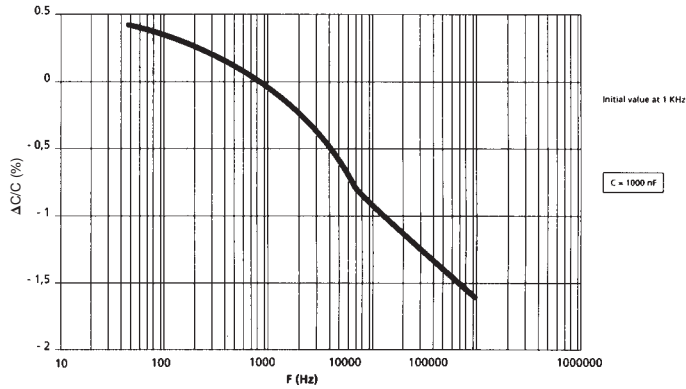

DISSIPATION FACTOR vs. FREQUENCY

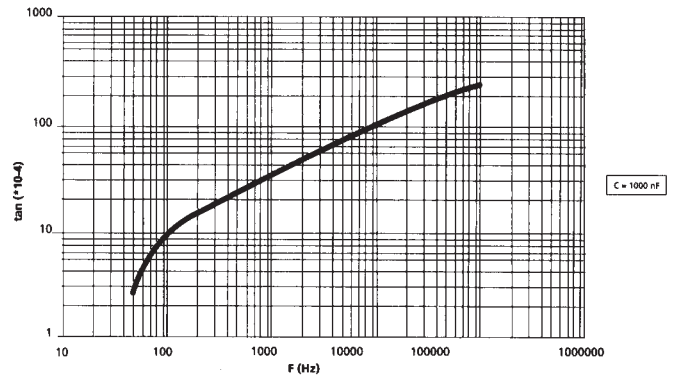

IMPEDANCE vs. FREQUENCY

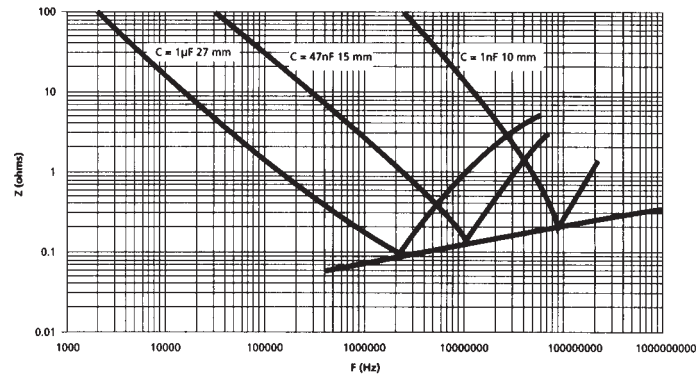

UEFF vs. FREQUENCY FOR DELTA TETA=10°C

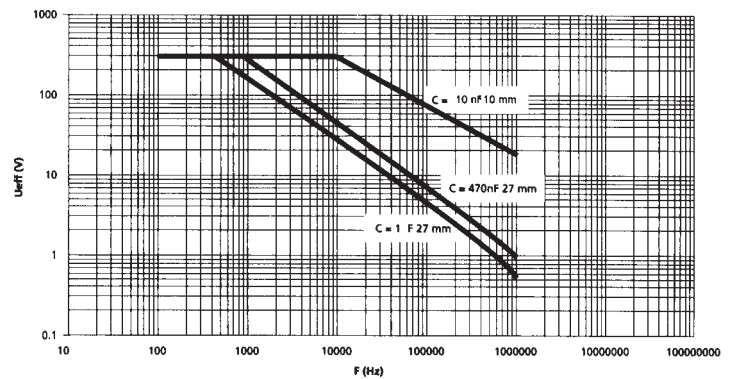

Nominal RMS voltage versus Frequency (room temperature) allowing a 10°C increase of the external temperature of the box.

PACKAGING: AUTOMATIC INSERTION

Pitch	D	E (ext)
10	360	48
15	500	52

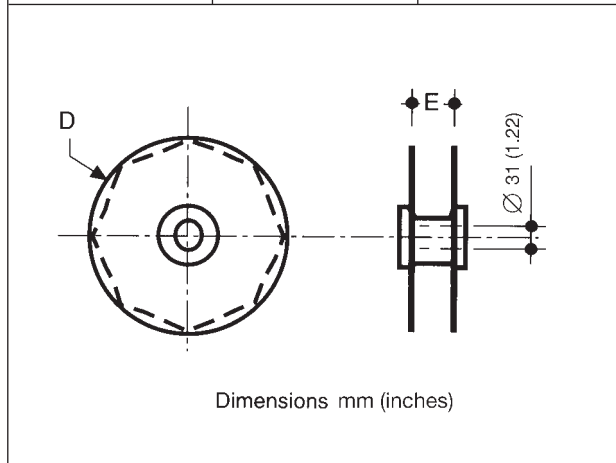

	Taping suffix EN	
	Dimensions millimeters (inches) d: lead spacing, tol. ± 0.4 ($\pm .016$)	
	10	15
P	25.4 ± 1 ($1 \pm .04$)	
H	16.5 ± 0.3 (.650 \pm .012)	$16^{+1.5}_{-0.5}$ (.630 ^{+.06} _{-.02})

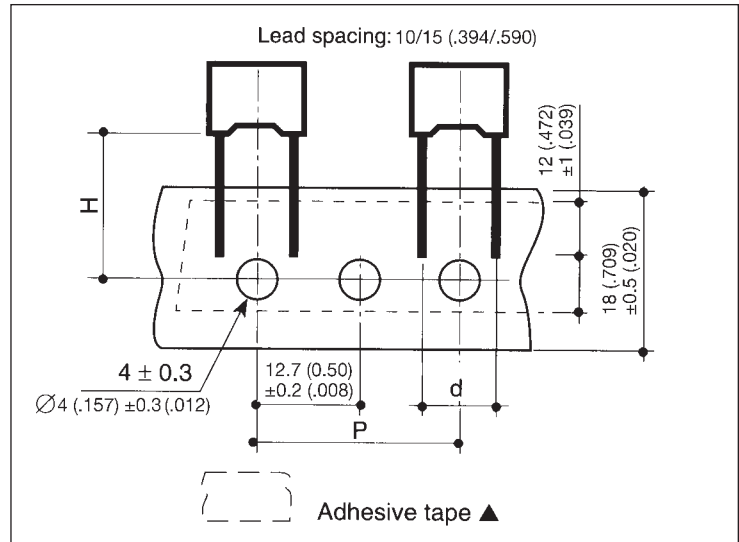

(Other sizes according to standard CEI : 286-2)

Dimensions millimeters (inches)

PACKAGING: PRIMARY QUANTITIES*

Size	Capacitance	Quantities Per Reel	Bulk Quantities / Lead Length		
			$l \leq 7$	$7 < l \leq 20$	$20 < l \leq 26$
10	1 nF to 4.7 nF	700	1250	1000	3000
	6.8 nF to 10 nF	700	1000	750	2000
15	10 nF to 47 nF	1000	750	750	2000
	68 nF	1000	3000	2500	2000
	100 nF	833	3000	2000	2000
	150 nF	625	2000	1500	1300
22	150 nF to 220 nF	—	2860	1000	1000
	330 nF to 470 nF	—	1672	600	600
27	470 nF	—	1368	500	500
	680 nF to 1 μ F	—	1080	350	350
	1.5 μ F	—	594	200	200
	2.2 μ F	—	486	150	150

*Ordering quantities must be a multiple of the above figures

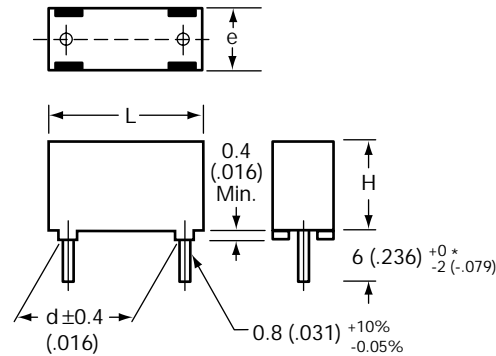

Dimensions mm (inches)
*Other lead lengths upon request

DESCRIPTION

Polypropylene film capacitors, insulated plastic case* with stand-offs, epoxy resin* sealed, radial lead outputs.

* Flame retardant materials (UL 94 V1)

GENERAL CHARACTERISTICS

Capacitance range	1 nF to 22 nF/E6 Series
Tolerance on capacitance	$\pm 10\%$, $\pm 20\%$
Rated voltage	$U_r = 250 \text{ Vac}$
Climatic category	40/085/21
RMS test voltage	- Between terminals $U_e \text{ rms: } 1.5 \text{ kV during } 1 \text{ mn}$ - Between shorted terminals and case $U_e \text{ rms: } 2 \text{ kV during } 1 \text{ mn}$
Tangent of loss angle	$Tg\delta \leq 20 \times 10^{-4}$
Insulation resistance	$R_i \geq 10 \text{ G}\Omega$
Life test 1000 h at 85°C	- RMS applied voltage $U_{rms}: 438 \text{ V (1.75 } U_r) +$ 1000 V during 0.1s per hour

APPLICATIONS

- Y function suppression capacitor ($U_{rms} = 250 \text{ V}$).
- Mains suppression, earth-mains connection, shock protection.
- Non-inductive, self-healing, insulated.

DIMENSIONS - CAPACITANCE VALUES

millimeters (inches)

Format Size	C _R (nF)	Dimensions			
		L max.	H max.	e max.	d ± 0.4
10	1 - 1.5 - 2.2	12.5 (.492)	10.0 (.394)	5.0 (.197)	10.0 (.394)
	3.3	12.5 (.492)	13.5 (.531)	5.0 (.197)	10.0 (.394)
15	4.7 / 6.8	17.5 (.689)	10.5 (.413)	5.0 (.197)	15.0 (.591)
	10	17.5 (.689)	13.5 (.531)	5.0 (.197)	15.0 (.591)
	15 - 22	17.5 (.689)	14.5 (.570)	8.5 (.335)	15.0 (.591)

APPROVALS

	VDE 0565-1	All models	File No. 49950
	IMQ	All models	File No. V2258
	DEMKO	All models	File No. 91975 EC
	SEMKO	All models	File No. 8850110
	FI SETI	All models	File No. 126107-01
	NEMKO	All models	File No. M 69061
	ÖVE	All models	File No. 19602/R
	UL 1283	All models	File No. 102673

MARKING

On upper edge

- Logo
- Capacitance and tolerance (IEC code)

On one side

- Approval Brands
- Type: CPY - MKP
- Nominal Voltage: 250 V ~
- Climatic Category: GPF 40/085/21
- Self-healing Code: SH

PACKAGING: AUTOMATIC INSERTION

Pitch	D	E (ext)
10	360	48
15	500	52

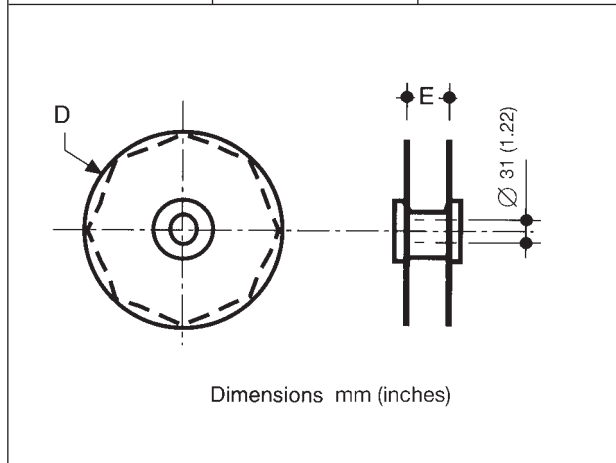

	Taping suffix EN	
	Dimensions millimeters (inches) d: lead spacing, tol. ± 0.4 ($\pm .016$)	
	10	15
P	25.4 ± 1 ($1 \pm .04$)	
H	16.5 ± 0.3 (.650 \pm .012)	$16^{+1.5}_{-0.5}$ (.630 ^{+.06} _{-.02})

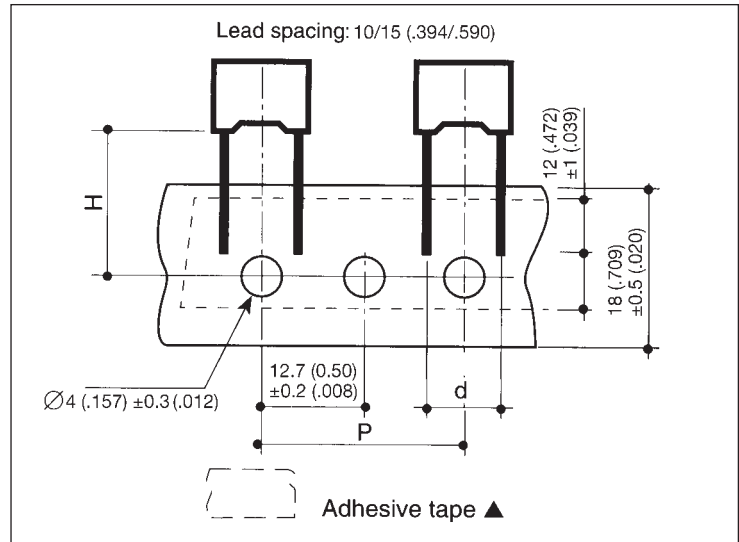

(Other sizes according to standard CEI : 286-2)

Dimensions millimeters (inches)

PACKAGING: PRIMARY QUANTITIES*

Size	Capacitance	Quantities Per Reel	Bulk Quantities / Lead Length		
			$l \leq 7$	$7 < l \leq 20$	$20 < l \leq 26$
10	1 nF to 2.2 nF	700	1250	1000	3000
	3.3 nF	700	1000	750	2000
15	4.7 to 6.8 nF	1000	750	750	2000
	10 nF	1000	3000	2500	2000
	15 nf to 22 nF	625	2000	1500	1300

*Ordering quantities must be a multiple of the above figures

USA

AVX Myrtle Beach, SC Corporate Offices

Tel: 843-448-9411
FAX: 843-448-1943

AVX Northwest, WA

Tel: 360-669-8746
FAX: 360-699-8751

AVX North Central, IN

Tel: 317-848-7153
FAX: 317-844-9314

AVX Northeast, MA

Tel: 508-485-8114
FAX: 508-485-8471

AVX Mid-Pacific, CA

Tel: 408-436-5400
FAX: 408-437-1500

AVX Southwest, AZ

Tel: 602-539-1496
FAX: 602-539-1501

AVX South Central, TX

Tel: 972-669-1223
FAX: 972-669-2090

AVX Southeast, NC

Tel: 919-878-6357
FAX: 919-878-6462

AVX Canada

Tel: 905-564-8959
FAX: 905-564-9728

EUROPE

AVX Limited, England European Headquarters

Tel: ++44 (0)1252 770000
FAX: ++44 (0)1252 770001

AVX S.A., France

Tel: ++33 (1) 69.18.46.00
FAX: ++33 (1) 69.28.73.87

AVX GmbH, Germany - AVX

Tel: ++49 (0) 8131 9004-0
FAX: ++49 (0) 8131 9004-44

AVX GmbH, Germany - Elco

Tel: ++49 (0) 2741 2990
FAX: ++49 (0) 2741 299133

AVX srl, Italy

Tel: ++390 (0)2 614571
FAX: ++390 (0)2 614 2576

AVX sro, Czech Republic

Tel: ++420 (0)467 558340
FAX: ++420 (0)467 558345

ASIA-PACIFIC

AVX/Kyocera, Singapore Asia-Pacific Headquarters

Tel: (65) 258-2833
FAX: (65) 350-4880

AVX/Kyocera, Hong Kong

Tel: (852) 2-363-3303
FAX: (852) 2-765-8185

AVX/Kyocera, Korea

Tel: (82) 2-785-6504
FAX: (82) 2-784-5411

AVX/Kyocera, Taiwan

Tel: (886) 2-2516-7010
FAX: (886) 2-2506-9774

AVX/Kyocera, China

Tel: (86) 21-6249-0314-16
FAX: (86) 21-6249-0313

AVX/Kyocera, Malaysia

Tel: (60) 4-228-1190
FAX: (60) 4-228-1196

Elco, Japan

Tel: 045-943-2906/7
FAX: 045-943-2910

Kyocera, Japan - AVX

Tel: (81) 75-604-3426
FAX: (81) 75-604-3425

Kyocera, Japan - KDP

Tel: (81) 75-604-3424
FAX: (81) 75-604-3425

Contact:



<http://www.avxcorp.com>

S-SCCX7M599-R