

# Low Inductance Chip Capacitors

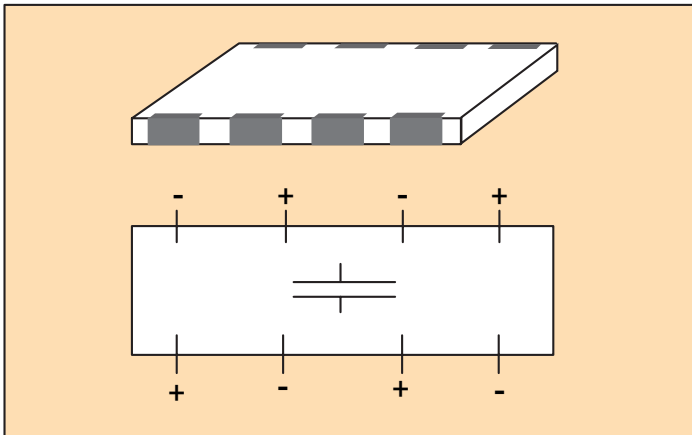

## InterDigitated Capacitor (IDC)



### GENERAL DESCRIPTION

AVX's interdigitated capacitor is a very low inductance, surface mount capacitor. A measured inductance of 175pH makes this the lowest, FR4 mountable device in the industry. With the high speed microprocessors approaching 500MHz, and beyond, the need for low inductance, decoupling caps becomes critical. Also, by connecting the device with eight (8) vias to the power and ground planes, the inductance of the entire system can be lowered. This allows engineers to speed up board interconnect for the current, and next generation, of microprocessors.

### HOW TO ORDER

<b>W</b>	<b>3</b>	<b>L</b>	<b>1</b>	<b>Y</b>	<b>C</b>	<b>105</b>	<b>M</b>	<b>A</b>	<b>T</b>	<b>3</b>	<b>A</b>
Style	Case Size	Low Inductance	Number of Caps	Voltage 6=6.3V Z=10V Y=16V	Dielectric C=X7R	Capacitance Code	Tolerance M=±20%	Terminations T= Plated Ni and Solder	Packaging Code (Reel Size) 1=7" Reel 3=13" Reel Embossed Tape	Special A=Standard F=1,000 Per Reel Only	

Package Style	Measured Inductance (pH)
IDC	175
Feedthru	375
0612	550
1206	1200

Capacitance (µF)	.047	0.1	0.22	0.47	0.68	1.0	2.2
X7R	16V						
	10V						
	6.3V						

### Impedance Characteristics of 1µF - X7R

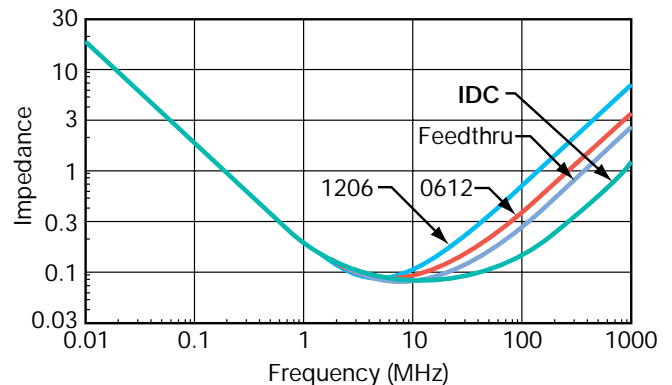

### Typical Impedance and ESR - 2.2µF - ESR

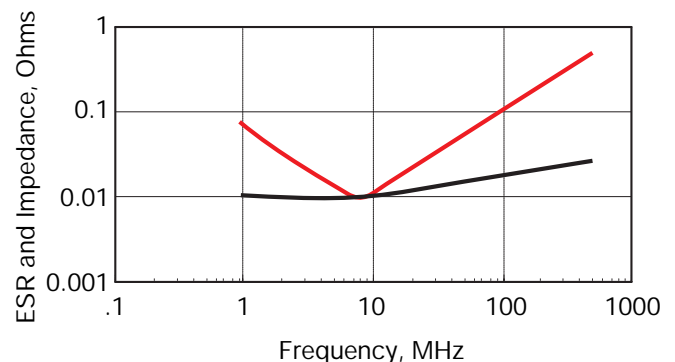

### PERFORMANCE CHARACTERISTICS

Capacitance Tolerance	<b>X7R</b> ±20%
Dissipation Factor	For 16 volts: 3.5% max. For 10 volts: 5% max. For 6.3 volts: 6.5% max.
Insulation Resistance (+25°C, VDC)	100,000MΩ min. or 1,000MΩ-µF min., whichever is less



# Low Inductance Chip Capacitors



## InterDigitated Capacitor (IDC)

### PHYSICAL DIMENSIONS AND PAD LAYOUT

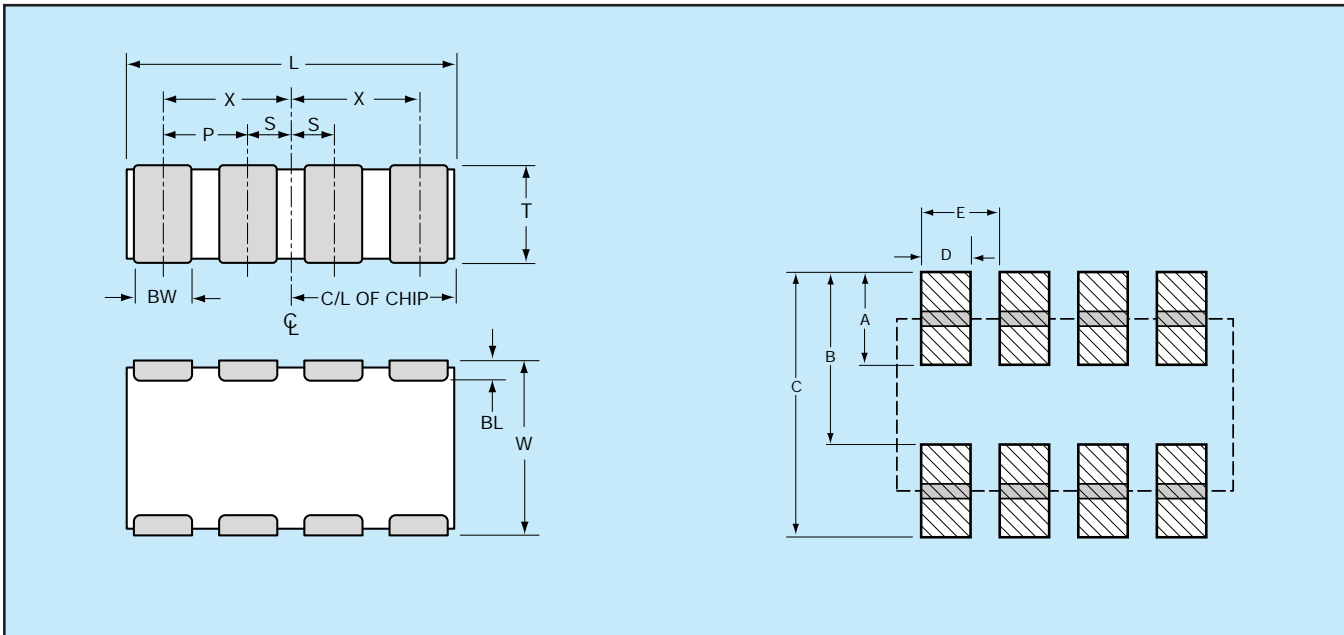

#### PART DIMENSIONS millimeters (inches)

L	W	T	BW	BL	P	X	S
3.20±0.2 (.126±.008)	1.60±0.2 (.063±.008)	1.22 MAX (.048 MAX)	0.41±0.1 (.016±.004)	0.18 <sup>+0.25</sup> <sub>-.08</sub> (.007 <sup>+0.10</sup> <sub>-.003</sub> )	0.76 REF (.030 REF)	1.14±0.1 (.045±.004)	0.38±0.1 (.015±.004)

#### PAD LAYOUT DIMENSIONS

A	B	C	D	E
0.89 (.035)	1.65 (.065)	2.54 (.100)	0.46 (.018)	0.79 (.030)

#### ASSEMBLY NOTES

AVX recommends a minimum spacing of 0.020" between parts when placing them end to end on assembly boards. The purpose of this spacing is to facilitate post assembly board cleaning and inaccuracies in pick and placement, due to machine placement tolerances.