

# Thin-Film Directional Couplers



## CP0603 SMD Type

### GENERAL DESCRIPTION ITF (Integrated Thin-Film) TECHNOLOGY

The ITF SMD Coupler is based on thin-film multilayer technology. The technology provides a miniature part with excellent high frequency performance and rugged construction for reliable automatic assembly. The ITF Coupler is offered in a variety of frequency bands compatible with various types of high frequency wireless systems.

### APPLICATIONS

- Mobile Communications
- Satellite TV Receivers
- GPS
- Vehicle Location Systems
- Wireless LAN's

### FEATURES

- Miniature Size: 0603
- Frequency Range: 800MHz - 3GHz
- Characteristic Impedance: 50Ω
- Operating / Storage Temp.: -40°C to +85°C
- Power Rating: 3W Continuous
- Low Profile
- Rugged Construction
- Taped and Reeled

### DIMENSIONS:

millimeters (inches)

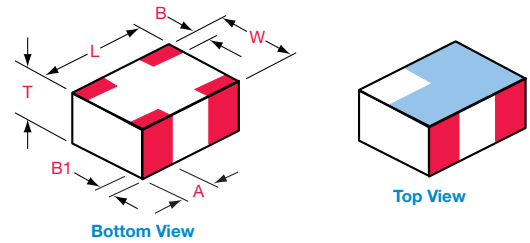

	0603
L	1.6±0.1 (0.063±0.004)
W	0.84±0.1 (0.033±0.004)
T	0.60±0.1 (0.028±0.004)
A	0.35±0.15 (0.014±0.006)
B	0.175±0.1 (0.007±0.004)
B1	0.00+0.1/0-0.0 (0.00+0.004/-0.0)

3

### HOW TO ORDER

<b>CP</b>  <b>Style</b> Directional Coupler	<b>0603</b>  <b>Size</b> 0603	<b>X</b>  <b>Type</b>	<b>****</b>  <b>Frequency</b> MHz	<b>X</b>  <b>Sub Type</b>	<b>S</b>  <b>Termination Code</b> W = Sn90, Pb10 **S = Sn100 **RoHS Compliant	<b>TR</b>  <b>Packaging Code</b> TR = Tape and Reel
--	--	-----------------------------	--	---------------------------------	--	--



Please select correct termination style

### QUALITY INSPECTION

Finished parts are 100% tested for electrical parameters and visual characteristics. Each production lot is evaluated on a sample basis for:

- Static Humidity: 85°C, 85% RH, 160 hours
- Endurance: 125°C, I<sub>R</sub>, 4 hours

### TERMINATION

Nickel/Solder coating compatible with automatic soldering technologies: reflow, wave soldering, vapor phase and manual.

### Recommended Pad Layout Dimensions mm (inches)

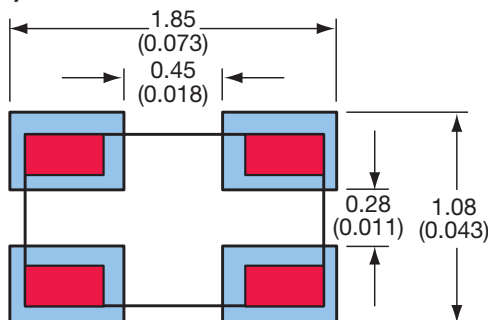

### TERMINALS (Top View)

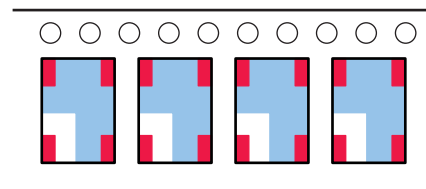
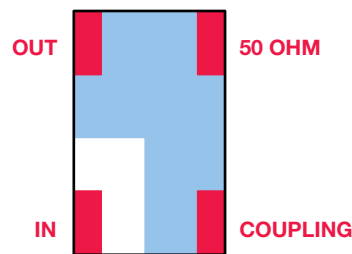

Orientation in tape

# Thin-Film Directional Couplers



## CP0603 SMD Type

Coupler P/N CP0603A\*\*\*\*AW

Application	P/N Examples	Frequency Band [MHz]	Coupling [dB]	I. Loss max	VSWR max
AMPS	CP0603A0836AW	824 - 849	18.5±1	0.25	1.2
	CP0603A0881AW	869 - 894	18.5±1		
GSM	CP0603A0902AW	890 - 915	18±1	0.25	
	CP0603A0947AW	935 - 960	17.5±1		
E-GSM	CP0603A0897AW	880 - 915	18±1	0.25	
	CP0603A0942AW	925 - 960	17.5±1		
PDC	CP0603A1441AW	1429 - 1453	14±1	0.4	
PCN	CP0603A1747AW	1710 - 1785	12.5±1	0.6	
	CP0603A1842AW	1805 - 1880	12±1		
PCS	CP0603A1880AW	1850 - 1910	12±1	0.65	
	CP0603A1960AW	1930 - 1990	11.5±1		
PHP	CP0603A1907AW	1895 - 1920	12±1	0.6	
DECT	CP0603A1890AW	1880 - 1900	12±1	0.6	
Wireless LAN	CP0603A2442AW	2400 - 2484	10±1	0.85	

P/N CP0603A\*\*\*\*AW

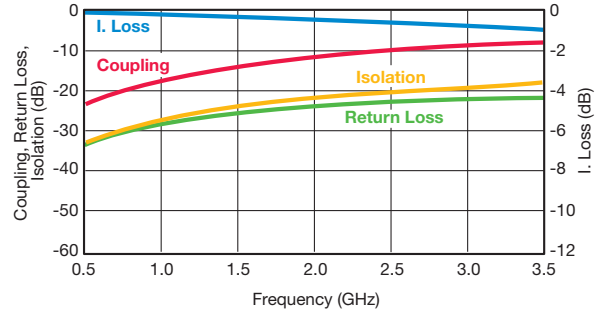

Coupler P/N CP0603A\*\*\*\*BW

Application	P/N Examples	Frequency Band [MHz]	Coupling [dB]	I. Loss max	VSWR max
AMPS	CP0603A0836BW	824 - 849	16±1	0.25	1.2
	CP0603A0881BW	869 - 894	15.5±1		
GSM	CP0603A0902BW	890 - 915	15.5±1	0.25	
	CP0603A0947BW	935 - 960	15±1		
E-GSM	CP0603A0897BW	880 - 915	15.5±1	0.55	
	CP0603A0942BW	925 - 960	15±1		
PDC	CP0603A1441BW	1429 - 1453	11.5±1	0.55	
PCN	CP0603A1747BW	1710 - 1785	10±1	0.8	1.3
	CP0603A1842BW	1805 - 1880	9.5±1		
PCS	CP0603A1880BW	1850 - 1910	9±1	0.8	1.4
	CP0603A1960BW	1930 - 1990	9±1		
PHP	CP0603A1907BW	1895 - 1920	9±1	0.8	
DECT	CP0603A1890BW	1880 - 1900	9±1	0.8	
Wireless LAN	CP0603A2442BW	2400 - 2484	7.5±1	1.1	

CP0603A\*\*\*\*BW

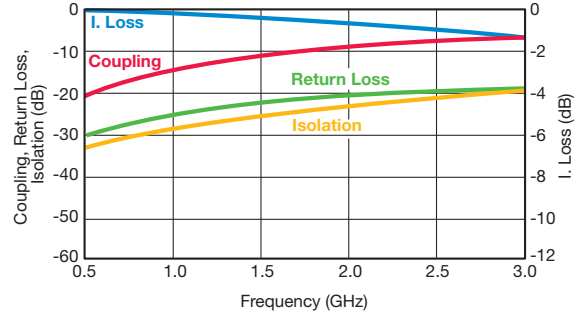

Coupler P/N CP0603A\*\*\*\*CW

Application	P/N Examples	Frequency Band [MHz]	Coupling [dB]	I. Loss max	VSWR max
AMPS	CP0603A0836CW	824 - 849	21±1	0.25	1.2
	CP0603A0881CW	869 - 894	20.5±1		
GSM	CP0603A0902CW	890 - 915	20.5±1	0.25	
	CP0603A0947CW	935 - 960	20±1		
E-GSM	CP0603A0897CW	880 - 915	20.5±1	0.25	
	CP0603A0942CW	925 - 960	20±1		
PDC	CP0603A1441CW	1429 - 1453	16.5±1	0.40	
PCN	CP0603A1747CW	1710 - 1785	15±1	0.5	
	CP0603A1842CW	1805 - 1880	14.5±1		
PCS	CP0603A1880CW	1850 - 1910	14.5±1	0.5	
	CP0603A1960CW	1930 - 1990	14±1		
PHP	CP0603A1907CW	1895 - 1920	14.5±1	0.5	
DECT	CP0603A1890CW	1880 - 1900	14.5±1	0.5	
Wireless LAN	CP0603A2442CW	2400 - 2484	12.5±1	0.65	

CP0603A\*\*\*\*CW

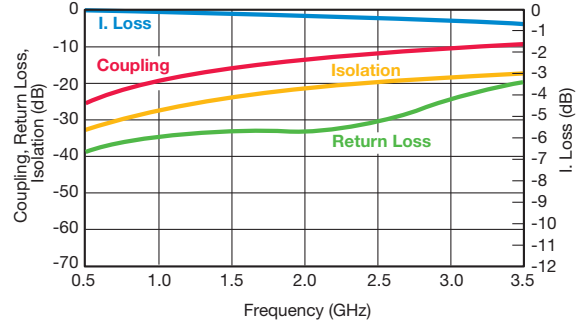

Coupler P/N CP0603A\*\*\*\*DW

Application	P/N Examples	Frequency Band [MHz]	Coupling [dB]	I. Loss max	VSWR max
AMPS	CP0603A0836DW	824 - 849	15.0±1	0.40	1.2
	CP0603A0881DW	869 - 894	14.5±1		
GSM	CP0603A0902DW	890 - 915	14.5±1	0.40	
	CP0603A0947DW	935 - 960	14±1		
E-GSM	CP0603A0897DW	880 - 915	14.5±1	0.40	
	CP0603A0942DW	925 - 960	14±1		
PDC	CP0603A1441DW	1429 - 1453	10.5±1	0.7	
PCN	CP0603A1747DW	1710 - 1785	9±1	0.9	1.3
	CP0603A1842DW	1805 - 1880	8.5±1		
PCS	CP0603A1880DW	1850 - 1910	8.5±1	1.0	1.5
	CP0603A1960DW	1930 - 1990	8±1		
PHP	CP0603A1907DW	1895 - 1920	8.5±1	1.0	
DECT	CP0603A1890DW	1880 - 1900	8.5±1	1.0	
Wireless LAN	CP0603A2442DW	2400 - 2484	6.5±1	1.5	

CP0603A\*\*\*\*DW

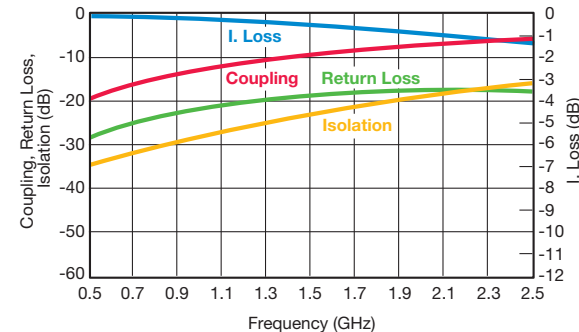

Important: Couplers can be used at any frequency within the indicated range.



# Thin-Film Directional Couplers



## CP0603 SMD Type

Coupler P/N CP0603B\*\*\*\*AW

Application	P/N Examples	Frequency Band [MHz]	Coupling [dB]	I. Loss max	VSWR max	
AMPS	CP0603B0836AW	824 - 849	24.5±1	0.2	1.2	
	CP0603B0881AW	869 - 894	24±1			
GSM	CP0603B0902AW	890 - 915	24±1			
	CP0603B0947AW	935 - 960	23.5±1			
E-GSM	CP0603B0897AW	880 - 915	24±1			0.25
	CP0603B0942AW	925 - 960	23.5±1			
PDC	CP0603B1441AW	1429 - 1453	20±1	0.3		
PCN	CP0603B1747AW	1710 - 1785	18±1			
	PCS	CP0603B1842AW	1805 - 1880	17.5±1		0.45
CP0603B1880AW		1850 - 1910	17.5±1			
PHP	CP0603B1960AW	1930 - 1990	17.5±1	0.45		
	CP0603B1907AW	1895 - 1920	17.5±1			
DECT	CP0603B1890AW	1880 - 1900	17.5±1	0.45		
Wireless LAN	CP0603B2442AW	2400 - 2484	15.5±1			

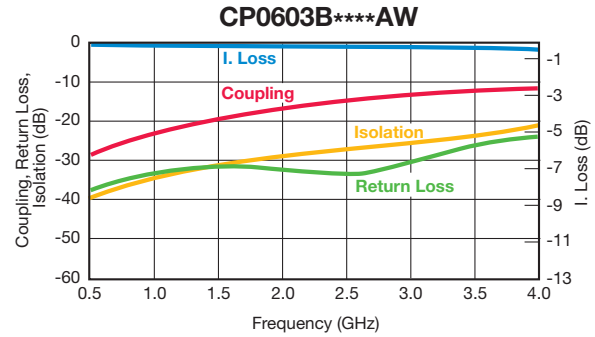

Coupler P/N CP0603B\*\*\*\*BW

Application	P/N Examples	Frequency Band [MHz]	Coupling [dB]	I. Loss max	VSWR max	
AMPS	CP0603B0836BW	824 - 849	25.5±1	0.2	1.2	
	CP0603B0881BW	869 - 894	25±1			
GSM	CP0603B0902BW	890 - 915	25±1			
	CP0603B0947BW	935 - 960	24.5±1			
E-GSM	CP0603B0897BW	880 - 915	25±1			0.25
	CP0603B0942BW	925 - 960	24.5±1			
PDC	CP0603B1441BW	1429 - 1453	21±1	0.25		
PCN	CP0603B1747BW	1710 - 1785	19±1			
	PCS	CP0603B1842BW	1805 - 1880	19±1		0.35
CP0603B1880BW		1850 - 1910	18.5±1			
PHP	CP0603B1960BW	1930 - 1990	18.5±1	0.35		
	CP0603B1907BW	1895 - 1920	18.5±1			
DECT	CP0603B1890BW	1880 - 1900	18.5±1	0.35		
Wireless LAN	CP0603B2442BW	2400 - 2484	16.5±1			

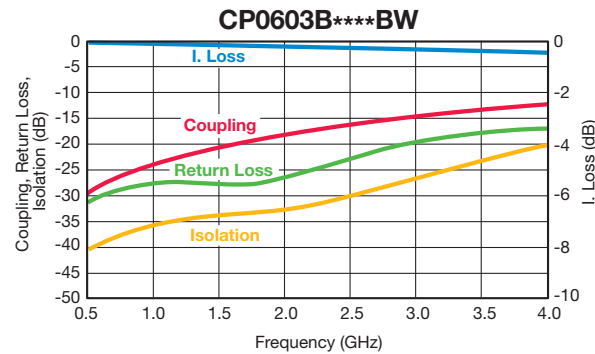

Coupler P/N CP0603B\*\*\*\*CW

Application	P/N Examples	Frequency Band [MHz]	Coupling [dB]	I. Loss max	VSWR max	
AMPS	CP0603B0836CW	824 - 849	26.5±1	0.2	1.2	
	CP0603B0881CW	869 - 894	26±1			
GSM	CP0603B0902CW	890 - 915	26±1			
	CP0603B0947CW	935 - 960	25.5±1			
E-GSM	CP0603B0897CW	880 - 915	26±1			0.25
	CP0603B0942CW	925 - 960	25.5±1			
PDC	CP0603B1441CW	1429 - 1453	22±1	0.25		
PCN	CP0603B1747CW	1710 - 1785	20.5±1			
	PCS	CP0603B1842CW	1805 - 1880	20±1		0.35
CP0603B1880CW		1850 - 1910	20±1			
PHP	CP0603B1960CW	1930 - 1990	19.5±1	0.35		
	CP0603B1907CW	1895 - 1920	20±1			
DECT	CP0603B1890CW	1880 - 1900	20±1	0.35		
Wireless LAN	CP0603B2442CW	2400 - 2484	18±1			

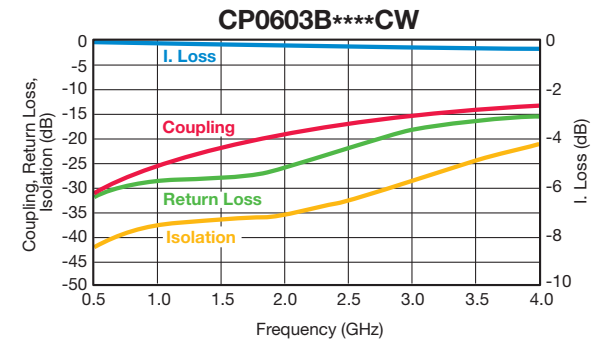

Important: Couplers can be used at any frequency within the indicated range.

# Thin-Film Directional Couplers



## CP0603 SMD Type – High Directivity

Coupler P/N CP0603D\*\*\*\*AW

Application	P/N Examples	Frequency Band [MHz]	Coupling [dB]	I. Loss max. [dB]	Return Loss [dB]	Directivity [dB]
AMPS	CP0603D0836AW	824 - 849	13.50	0.50	23	21
	CP0603D0881AW	869 - 894	13.00			
GSM	CP0603D0902AW	890 - 915	12.50	1.40	16	17
	CP0603D0947AW	935 - 960	13.00			
E-GSM	CP0603D0897AW	880 - 915	12.50	2.00	15	15
	CP0603D0942AW	925 - 960	9.00			
PDC	CP0603D1441AW	1429 - 1453	8.00	7.50	17	18
PCN	CP0603D1747AW	1710 - 1785	7.00			
PCS	CP0603D1842AW	1805 - 1880	7.00	1.40	16	17
	CP0603D1880AW	1850 - 1910	7.00			
PHP	CP0603D1960AW	1930 - 1990	7.00	1.40	16	17
DECT	CP0603D1907AW	1895 - 1920	7.00			
Wireless LAN	CP0603D1890AW	1880 - 1900	7.00	2.00	15	15
	CP0603D2442AW	2400 - 2484	5.50			

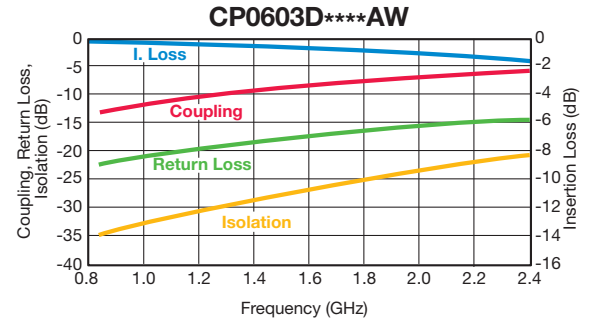

Coupler P/N CP0603D\*\*\*\*BW

Application	P/N Examples	Frequency Band [MHz]	Coupling [dB]	I. Loss max. [dB]	Return Loss [dB]	Directivity [dB]
AMPS	CP0603D0836BW	824 - 849	20.00	0.25	36	19
	CP0603D0881BW	869 - 894	19.50			
GSM	CP0603D0902BW	890 - 915	19.00	0.55	27	19
	CP0603D0947BW	935 - 960	19.00			
E-GSM	CP0603D0897BW	880 - 915	19.00	0.70	24	19
	CP0603D0942BW	925 - 960	19.00			
PDC	CP0603D1441BW	1429 - 1453	15.50	11.00	24	19
PCN	CP0603D1747BW	1710 - 1785	14.00			
PCS	CP0603D1842BW	1805 - 1880	13.50	0.55	27	19
	CP0603D1880BW	1850 - 1910	13.00			
PHP	CP0603D1960BW	1930 - 1990	13.00	0.70	24	19
DECT	CP0603D1907BW	1895 - 1920	13.00			
Wireless LAN	CP0603D1890BW	1880 - 1900	13.00	0.70	24	19
	CP0603D2442BW	2400 - 2484	11.00			

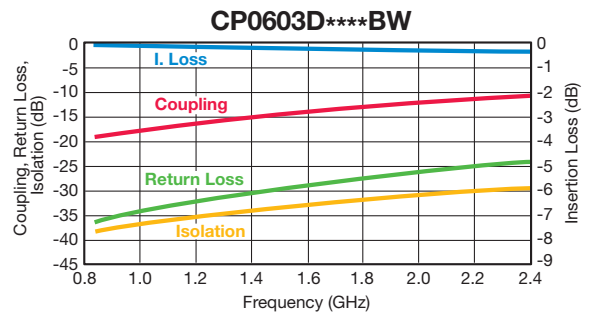

3

Important: Couplers can be used at any frequency within the indicated range.



# Thin-Film Directional Couplers



## CP0805 and CP0603 Test Jig

### ITF TEST JIG FOR COUPLER TYPES 0805 AND 0603 SMD

#### GENERAL DESCRIPTION

This jig is designed for the testing of CP0805 and CP0603 series Directional Couplers using a vector network analyzer. It consists of a FR4 multi-layer substrate, having 50Ω microstrips as conducting lines and a ground plane in the middle layer, located at a distance of 0.2mm from the microstrips.

The connectors are SMA type (female), 'Johnson Components Inc.' Product P/N: 142-0701-881.

The jig is designed for a full 2-port calibration. LOAD calibration can be done either by a 50Ω SMA termination, or by soldering a 50Ω chip resistor at the 50Ω ports.

#### MEASUREMENT PROCEDURE

When measuring a component, it can be either soldered or pressed by a non-metallic stick until all four ports touch the appropriate pads. To measure the coupling (and the R. Loss) place the component on the Port 1 & Port 2 pads. Use two SMA 50Ω terminations (male) to terminate the ports, which are not connected to the network analyzer, and connect the network analyzer to the two ports. A 90° rotation of the component on its pads allows measuring a second parameter (I. Loss).

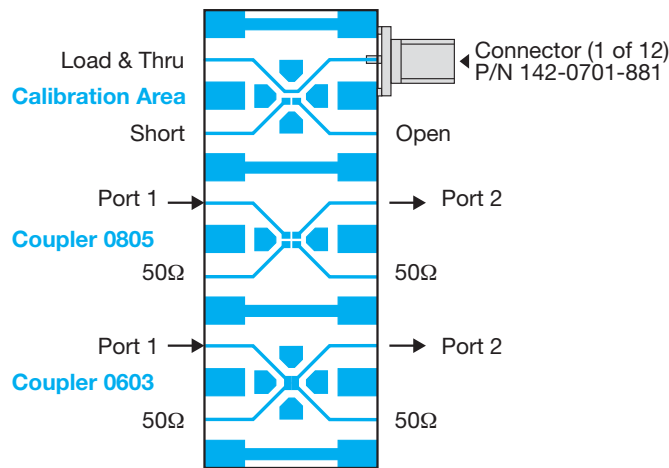

### CP0805 SERIES DIRECTIONAL COUPLERS

#### Orientation and Tape and Reel Packaging Specification

(Top View)

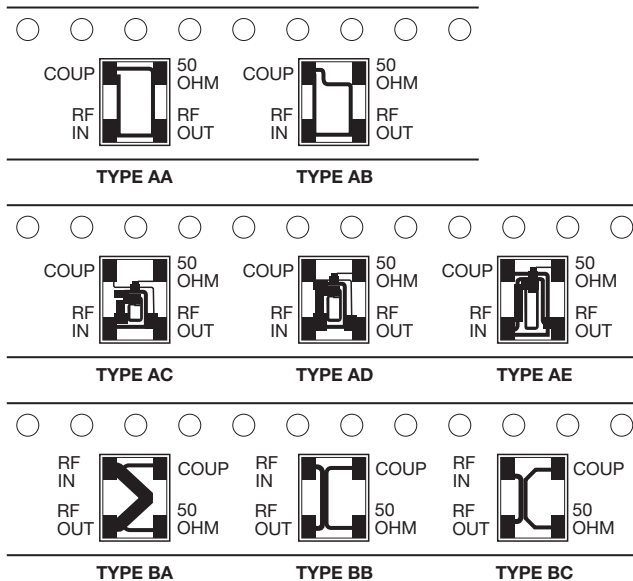

The parts should be mounted on the PCB with White (Alumina) side down and the "dark" side up.

#### CP0805xxxxxxSTR (Sn100)

(Top View)

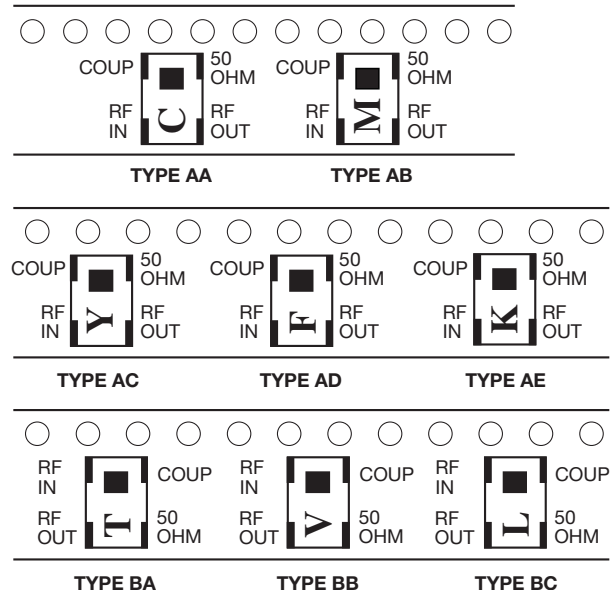

The parts should be mounted on the PCB with printed side up.